

Features

- High-density family of Field-Programmable Gate Arrays (FPGAs)
- Design- and process-optimized for low cost
 - 0.6- μ m three-layer metal (TLM) process
- System performance up to 50 MHz
- SRAM-based, in-system reprogrammable architecture
- Flexible architecture with abundant routing resources
 - VersaBlock™ logic module
 - VersaRing™ I/O interface
 - Dedicated cell-feedthrough path
 - Hierarchical interconnect structure
 - Extensive registers/latches
 - Dedicated carry logic for arithmetic functions
 - Cascade chain for wide input functions
 - Dedicated IEEE 1149.1 boundary-scan logic
 - Internal 3-state bussing capability
 - Four global low-skew clock or signal distribution nets
 - Globally selectable CMOS or TTL input thresholds
 - Output slew-rate control
 - 8-mA sink current per output
- Configured by loading binary file
 - Unlimited reprogrammability
 - Seven programming modes, including high-speed Express™ mode
- 100% factory tested
- 100% footprint compatibility for common packages

- Fully supported by XACTstep™ Development System
 - Includes complete support for XACT-Performance™, X-BLOX™, Unified Libraries, Relationally Placed Macros (RPMs), XDelay, and XChecker™
 - Wide selection of PC and workstation platforms
 - Interfaces to more than 100 third-party CAE tools

Description

The XC5200 Field-Programmable Gate Array Family is engineered to deliver the lowest cost of any FPGA family. By optimizing the new XC5200 architecture for three-layer metal (TLM) technology and a 0.6- μ m CMOS SRAM process, dramatic advances have been made in silicon efficiency. These advances position the XC5200 family as a cost-effective, high-volume alternative to gate arrays.

Building on experiences gained with three previous successful SRAM FPGA families, the XC5200 family brings a robust feature set to high-density programmable logic design. The VersaBlock logic module, the VersaRing I/O interface, and a rich hierarchy of interconnect resources combine to enhance design flexibility and reduce time-to-market.

Complete support for the XC5200 family is delivered through the familiar XACTstep software environment. The XC5200 family is fully supported on popular workstation and PC platforms. Popular design entry methods are fully supported, including ABEL, schematic capture, and synthesis. Designers utilizing logic synthesis can use their existing tools to design with the XC5200 devices.

Table 1: Initial XC5200 Field-Programmable Gate Array Family Members

Device	XC5202	XC5204	XC5206	XC5210	XC5215
Max Logic Gates	3,000	6,000	10,000	16,000	23,000
Typical Gate Range	2,000 - 3,000	4,000 - 6,000	6,000 - 10,000	10,000 - 16,000	15,000 - 23,000
VersaBlock Array	8 x 8	10 x 12	14 x 14	18 x 18	22 x 22
Number of CLBs	64	120	196	324	484
Number of Flip-Flops	256	480	784	1,296	1,936
Number of I/Os	84	124	148	196	244
TBUFs per Horizontal Longline	10	14	16	20	24

XC5200 Family Compared to XC4000 and XC3000 Series

For readers already familiar with the XC4000 and XC3000 gate array series, this section describes significant differences between them and the XC5200 family. Unless otherwise indicated, comparisons refer to both XC4000 and XC3000 devices.

Configurable Logic Block (CLB) Resources

Each XC5200 CLB contains four independent 4-input function generators and four registers, which are configured as four independent Logic Cells™ (LCs). The output from the function generator in each LC can be brought out as a CLB output and/or drive the D input of the register. A pair of LCs can be combined to form a 5-input function generator.

There are four direct feedthrough paths for each XC5200 CLB, one per LC. These paths provide extra data input lines or serve as additional local routes without consuming any logic resources.

The registers in each XC5200 LC are optionally configurable as edge-triggered D-type flip-flops or as transparent level-sensitive latches.

The XC5200 CLB includes dedicated carry logic that provides fast arithmetic carry capability. The dedicated carry logic may also be used to cascade function generators for implementing wide arithmetic functions.

XC4000 family: XC5200 devices have no wide edge decoders.

XC4000 family: XC5200 dedicated carry logic differs from that of the XC4000 family in that the sum is generated in an additional function generator in the adjacent column. An XC5200 device thus uses twice as many function generators for adders, subtractors, accumulators, and some counters. Note, however, that a loadable up/down counter requires the same number of function generators in both families.

XC4000 family: XC5200 lookup tables cannot be used as RAM.

Table 2: Four Generations of Xilinx Field-Programmable Gate Array Families

Parameter	XC5200	XC4000	XC3000A/XC3100A	XC2000
Function generators per CLB	4	3	2	2
Logic inputs per CLB	20	9	5	4
Logic outputs per CLB	12	4	2	2
Low-skew global buffers	4	8	2	2
Single-length lines	10	8	5	4
Double-length lines	4	4	0	0
Longlines	8	6	3	2
Direct connects	8	0	2	2
VersaRing	yes	no	no	no
User RAM	no	yes	no	no
Dedicated decoders	no	yes	no	no
Cascade chain	yes	no	no	no
Fast carry logic	yes	yes	no	no
Internal 3-state drivers	yes	yes	yes	no
IEEE boundary scan	yes	yes	no	no
Output slew-rate control	yes	yes	yes	no
Power-down option	no	no	yes	yes
Crystal oscillator circuit	no	no	yes	yes

Input/Output Block (IOB) Resources

The XC5200 family maintains footprint compatibility with the XC4000 family, but not with the XC3000 family.

The XC5200 IOB does not include flip-flops or latches. The XC5200 family provides direct connections from each IOB to the registers in the adjacent CLB in order to emulate IOB registers.

The XC5200 IOB provides a programmable delay element to control input set-up time. This element can be used to avoid potential hold-time problems.

Each XC5200 IOB is capable of 8-mA source and sink currents.

IEEE 1149.1-type boundary scan is supported in each XC5200 IOB.

XC3000 family: Each XC5200 IOB has access to tristatable Longlines by means of its own 3-state buffer (TBUF).

Routing Resources

The XC5200 family provides a flexible coupling of logic and local routing resources called the VersaBlock. The XC5200 VersaBlock element includes the CLB, a Local Interconnect Matrix (LIM), and direct connects to neighboring VersaBlocks.

Each XC5200 VersaBlock element has complete intra-CLB routing, the LIM, and offers four direct routing connections to each of the four neighboring CLBs. Any function generator or flip-flop thus has unrestricted connectivity to 19 other function generators or flip-flops: three in its own CLB, and 16 in the adjacent CLBs. These direct connects do not compete with the general routing resources (see Table 2).

There is a special routing resource, the VersaRing, between the outer edge of the core CLB array and the ring of IOBs, providing added routability to the I/O. This feature is particularly important for designs that require a fixed pinout prior to completion.

The XC5200 provides four global buffers for clocking or high-fanout control signals. Each buffer may be sourced by means of its dedicated pad or from any internal source.

Each XC5200 TBUF can drive up to two horizontal Longlines.

There are no internal pull-ups for XC5200 Longlines.

Configuration and Readback

XC4000 family: The XC5200 family provides a global reset but not a global set.

XC5200 devices use a different configuration process than that of the XC3000 family, but use the same process as the XC4000 family. The rest of this discussion compares XC5200 features with those of the XC3000 family only.

Although their configuration processes differ, XC5200 devices may be used in daisy chains with XC3000 devices.

The XC5200 PROGRAM pin is a single-function input pin that overrides all other inputs.

The XC5200 INIT pin also acts as a Configuration Error output.

XC5200 devices support two additional programming modes: Peripheral Synchronous and the new high-speed Express mode.

XC5200 start-up can be synchronized to any user clock by means of a configuration option.

The XC5200 family does not support Power-down, but offers a Global 3-state input that does not reset any flip-flops.

The XC5200 family does not provide an on-chip crystal oscillator amplifier, but it does provide an internal oscillator from which a variety of frequencies up to 16 MHz are available.

Readback in the XC5200 family either ignores the flip-flop content, thereby avoiding the need for masking, or it takes a snapshot of all flip-flops at the start of Readback.

Readback in the XC5200 family has the same polarity as Configuration, and can be aborted.

Architectural Overview

Figure 1 presents a simplified, conceptual overview of the XC5200 architecture. Similar to conventional FPGAs, the XC5200 family consists of programmable IOBs, programmable logic blocks, and programmable interconnect. Unlike other FPGAs, however, the logic and local routing resources of the XC5200 family are combined in flexible VersaBlocks. General-purpose routing connects to the VersaBlock through the General Routing Matrix (GRM).

VersaBlock: Abundant Local Routing Plus Versatile Logic

The basic logic element in each VersaBlock structure is the Logic Cell, shown in Figure 2. Each LC contains a 4-input function generator (F), a storage device (FD), and control logic. There are five independent inputs and three outputs to each LC. The independence of the inputs and outputs allows the software to maximize the resource utilization within each LC. Each Logic Cell also contains a direct feedthrough path that does not sacrifice the use of either the function generator or the register; this feature is a first for FPGAs. The storage device is configurable as either a D flip-flop or a latch. The control logic consists of carry logic for fast implementation of arithmetic functions, which can also be configured as a cascade chain allowing decode of very wide input functions.

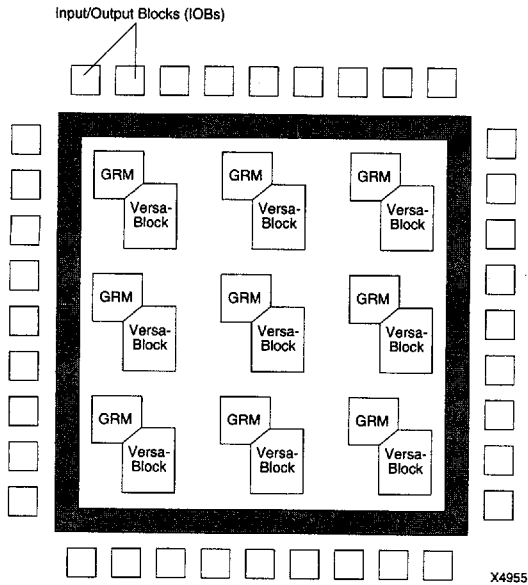

Figure 1: XC5200 Architectural Overview

The XC5200 CLB consists of four LCs, as shown in Figure 3. Each CLB has 20 independent inputs and 12 independent outputs. The top and bottom pairs of LCs can be configured to implement 5-input functions. The challenge of FPGA implementation software has always been to maximize the usage of logic resources. The XC5200 family addresses this issue by surrounding each CLB with two types of local interconnect — the Local Interconnect Matrix (LIM) and direct connects. These two interconnect resources, combined with the CLB, form the VersaBlock, represented in Figure 4.

The LIM provides 100% connectivity of the inputs and outputs of each LC in a given CLB. The benefit of the LIM is that no general routing resources are required to connect feedback paths within a CLB. The LIM connects to the GRM via 24 bidirectional nodes.

The direct connects allow immediate connections to neighboring CLBs, once again without using any of the general interconnect. These two layers of local routing resource improve the granularity of the architecture, effectively making the XC5200 family a "sea of logic cells." Each VersaBlock has four 3-state buffers that share a common enable line and directly drive horizontal Longlines, creating robust on-chip bussing capability. The VersaBlock allows fast, local implementation of logic functions, effectively implementing user designs in a hierarchical fashion. These resources also minimize local routing congestion and improve the efficiency of the general interconnect, which is used for connecting larger groups of logic. It is this combination of both fine-grain and coarse-grain architecture attributes that maximize logic utilization in the XC5200 family. This symmetrical structure takes full advantage of the third metal layer, freeing the placement software to pack user logic optimally with minimal routing restrictions.

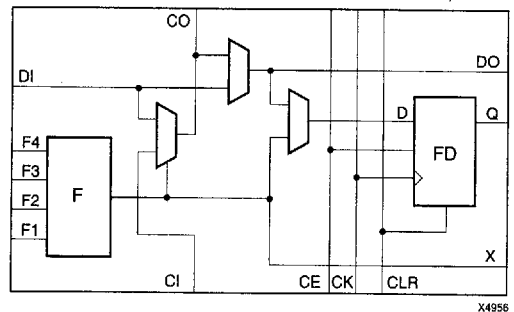

Figure 2: XC5200 Logic Cell (Four LCs per CLB)

VersaRing I/O Interface

The interface between the IOBs and core logic has been redesigned in the XC5200 family. The IOBs are completely decoupled from the core logic. The XC5200 IOBs contain dedicated boundary-scan logic for added board-level testability, but do not include input or output registers. This approach allows a maximum number of IOBs to be placed around the device, improving the I/O-to-gate ratio and decreasing the cost per I/O. A "freeway" of interconnect cells surrounding the device forms the VersaRing, which provides connections from the IOBs to the internal logic. These incremental routing resources provide abundant connections from each IOB to the nearest VersaBlock, in addition to Longline connections surrounding the device. The VersaRing eliminates the historic trade-off between high logic utilization and pin placement flexibility. These incremental edge resources give users increased flexibility in preassigning (i.e., locking) I/O pins before completing their logic designs. This ability accelerates time-to-market, since PCBs and other system components can be manufactured concurrent with the logic design.

General Routing Matrix

The GRM is functionally similar to the switch matrices found in other architectures, but it is novel in its tight coupling to the logic resources contained in the VersaBlocks. Advanced simulation tools were used during the development of the XC5200 architecture to determine the optimal level of routing resources required. The XC5200 family contains six levels of interconnect hierarchy — a series of single-length lines, double-length lines, and Longlines all routed through the GRM. The direct connects, LIM, and logic-cell feedthrough are contained within each VersaBlock. Throughout the XC5200 interconnect, an efficient multiplexing scheme, in combination with three layer metal (TLM), was used to improve the overall efficiency of silicon usage.

Performance Overview

The XC5200 family has been benchmarked with many designs running synchronous clock rates up to 50 MHz. The performance of any design depends on the circuit to be implemented, and the delay through the combinatorial and sequential logic elements, plus the delay in the interconnect routing. Table 3 shows some performance numbers for representative circuits. A rough estimate of timing can be made by assuming 6 ns per logic level, which includes direct-connect routing delays. More accurate estimations can be made using the information in the Switching Characteristic Guideline section.

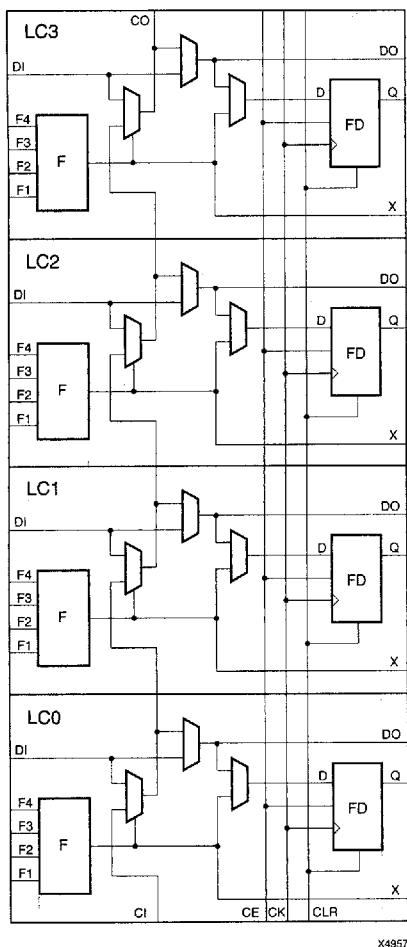

X4957

Figure 3: Configurable Logic Block

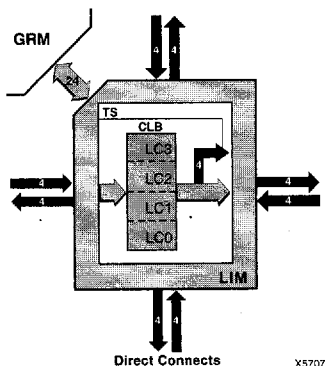

X5707

Figure 4: VersaBlock

9941759 0007697 469

Table 3: Performance for Several Common Circuit Functions

Function	XC5200 Speed Grade			
	-6	-5	-4	-3
16-bit Decoder from Input Pad	9 ns	8 ns	7 ns	6 ns
24-bit Accumulator	32 MHz	39 MHz	45 MHz	50 MHz
16-to-1 Multiplexer	16 ns	13 ns	11 ns	9 ns
16-bit Unidirectional Loadable Counter	40 MHz	50 MHz	59 MHz	65 MHz
16-bit U/D Counter	40 MHz	50 MHz	59 MHz	65 MHz
16-bit Adder	24 ns	20 ns	17 ns	15 ns
24-bit Loadable U/D Counter	36 MHz	42 MHz	48 MHz	52 MHz
			Preliminary	Advance

Development System

The powerful features of the XC5200 device family require an equally powerful, yet easy-to-use, set of development tools. Xilinx provides an enhanced version of the Xilinx Automatic CAE Tools (*XACTstep*), optimized for the XC5200 family.

As with other logic technologies, the basic methodology for XC5200 FPGA design consists of three interrelated steps: design entry, implementation, and verification. Popular generic tools are used for entry and simulation (for example, Viewlogic Systems's Viewdraw schematic editor and Viewsim simulator), but architecture-specific tools are needed for implementation.

Several advanced features of the *XACTstep* system facilitate XC5200 FPGA design. RPMs — schematic-based macros with relative location constraints to guide their placement within the FPGA — help to ensure an optimized implementation for common logic functions. An abundance of local routing permits RPMs to be contained within a single VersaBlock or to span across multiple VersaBlocks. *XACT-Performance* allows designers to enter the exact performance requirements during design entry, at the schematic level, to guide PPR.

Design Entry

Designs can be entered graphically, using schematic-capture software, or in any of several text-based formats (such as Boolean equations, state-machine descriptions, and high-level design languages).

Xilinx and third-party CAE vendors have developed library and interface products compatible with a wide variety of design-entry and simulation environments. A standard interface-file specification, Xilinx Netlist File (XNF), is provided to simplify file transfers into and out of the *XACTstep* development system.

Xilinx offers *XACTstep* development system interfaces to the following design environments:

- Xilinx Foundation Series
- Viewlogic Systems (Viewdraw, Viewsim)

- Mentor Graphics V8 (NETED, QuickSim, Design Architect, QuickSim II)
- OrCAD (SDT, VST)
- Synopsys (Design Compiler, FPGA Compiler)
- Xilinx-ABEL (State Machine module generator)
- X-BLOX (Graphical Mode Generator)

Many other environments are supported by third-party vendors. Currently, more than 100 packages are supported.

The unified schematic library for the XC5200 FPGA reflects the wide variety of logic functions that can be implemented in these versatile devices. The library contains over 400 primitives and macros, ranging from 2-input AND gates to 16-bit accumulators, and includes arithmetic functions, comparators, counters, data registers, decoders, encoders, I/O functions, latches, Boolean functions, multiplexers, shift registers, and barrel shifters.

Designing with macros is as easy as designing with standard SSI/MSI functions. The "soft macro" library contains detailed descriptions of common logic functions, but does not contain any partitioning or routing information. The performance of these macros depends, therefore, on how the PPR software processes the design. RPMs, on the other hand, do contain predetermined partitioning and relative placement information, resulting in an optimized implementation for these functions. Users can create their own library elements — either soft macros or RPMs — based on the macros and primitives of the standard library.

The X-BLOX design language is a graphics-based high-level description language (HDL) that allows designers to use a schematic editor to enter designs as a set of generic modules. The X-BLOX compiler synthesizes and optimizes the modules for the target device architecture, automatically choosing the appropriate architectural resources for each function.

The *XACTstep* design environment supports hierarchical design entry, with top-level drawings defining the major functional blocks, and lower-level descriptions defining the logic in each block. The implementation tools automatically combine the hierarchical elements of a design. Different

hierarchical elements can be specified with different design entry tools, allowing the use of the most convenient entry method for each portion of the design.

Design Implementation

The design implementation tools satisfy the requirements for an automated design process. Logic partitioning, block placement, and signal routing are performed by the PPR program. The partitioner takes the logic from the entered design and maps the logic into the architectural resources of the FPGA (such as the logic blocks, I/O blocks, and 3-state buffers). The placer then determines the best locations for the blocks, depending on their connectivity and the required performance. The router finally connects the placed blocks together.

The PPR algorithms support fully automatic implementation of most designs. However, for demanding applications, the user may exercise various degrees of control over the automated implementation process. Optionally, user-designated partitioning, placement, and routing information can be specified as part of the design-entry process. The implementation of highly structured designs can benefit greatly from the basic floorplanning techniques familiar to designers of large gate arrays.

The PPR program includes XACT-Performance, a feature that allows designers to specify the timing requirements along entire paths during design entry. Timing path analysis routines in PPR then recognize and accommodate the user-specified requirements. Timing requirements can be entered on the schematic in a form directly relating to the system requirements (such as the targeted minimum clock frequency, or the maximum allowable delay on the data path between two registers). So, while the timing of each individual net is not predictable, the overall performance of the system along entire signal paths is automatically tailored to match user-generated specifications.

Design Verification

The high development cost associated with common mask-programmed gate arrays necessitates extensive simulation to verify a design. Due to the custom nature of masked gate arrays, mistakes or last-minute design changes cannot be tolerated. A gate-array designer must simulate and test all logic using simulation software. Simulation describes what happens in a system under worst-case situations. However, simulation can be tedious and slow, and simulation vectors must be generated. A few seconds of system time can take weeks to simulate.

Programmable-gate-array users, however, can use in-circuit debugging techniques in addition to simulation. Because Xilinx devices are reprogrammable, designs can be verified in real time without the need for extensive simulation vectors.

The XACTstep development system supports both simulation and in-circuit debugging techniques. For simulation, the system extracts the post-layout timing information from the design database. This data can then be sent to the simulator to verify timing-critical portions of the design database using XDELAY, the Xilinx static timing analyzer tool. Back-annotation — the process of mapping the timing information back into the signal names and symbols of the schematic — eases the debugging effort.

For in-circuit debugging, the XACTstep development system includes a serial download and readback cable (XChecker) that connects the FPGA in the system to the PC or workstation through an RS232 serial port. The engineer can download a design or a design revision into the system for testing. The designer can also single-step the logic, read the contents of the numerous flip-flops on the device, and observe internal logic levels. Simple modifications can be downloaded into the system in a matter of minutes.

Detailed Functional Description

CLB Logic

Figure 3 shows the logic in the XC5200 CLB, which consists of four Logic Cells (LC[3:0]). Each Logic Cell consists of an independent 4-input Lookup Table (LUT), and a D-Type flip-flop or latch with common clock, clock enable, and clear, but individually selectable clock polarity. Additional logic features provided in the CLB are:

- High-speed carry propagate logic.
- High-speed pattern decoding.
- High-speed direct connection to flip-flop D-inputs.
- Each flip-flop can be programmed individually as either

- a transparent, level-sensitive latch or a D flip-flop.
- Four 3-state buffers with a shared Output Enable.
- Two 4-input LUTs can be combined to form an independent 5-input LUT.

5-Input Functions

Figure 5 illustrates how the outputs from the LUTs from LC0 and LC1 can be combined with a 2:1 multiplexer (F5_MUX) to provide a 5-input function. The outputs from the LUTs of LC2 and LC3 can be similarly combined.

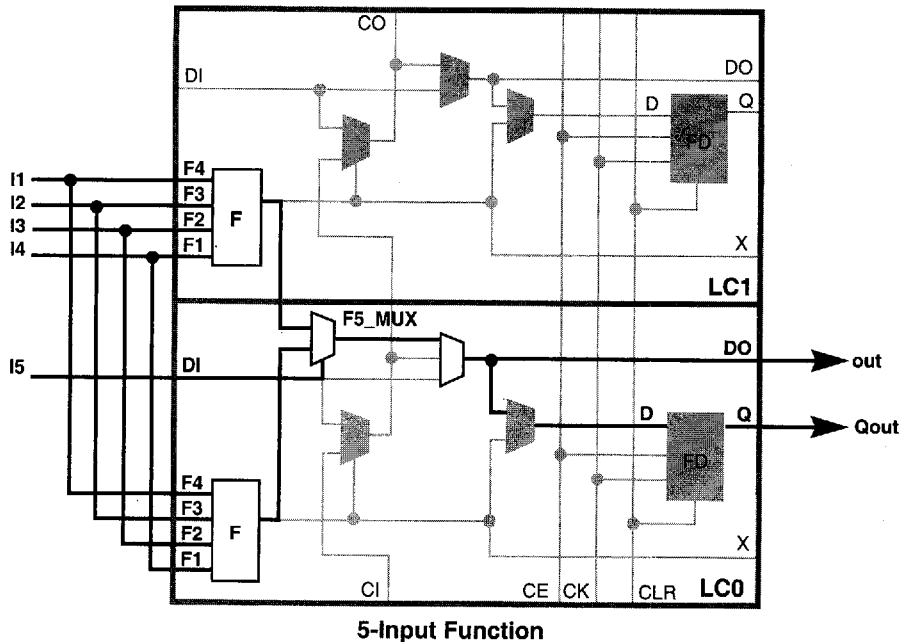

X5710

Figure 5: Two LUTs in Parallel Combined to Create a 5-input Function

Carry Function

The XC5200 family supports a carry-logic feature that enhances the performance of arithmetic functions such as counters, adders, etc. A carry multiplexer (CY_MUX) symbol on a schematic is used to indicate the XC5200 carry logic. This symbol represents the dedicated 2:1 multiplexer in each LC that performs the one-bit high-speed carry propagate per logic cell (four bits per CLB).

While the carry propagate is performed inside the LC, an adjacent LC must be used to complete the arithmetic function. Figure 6 represents an example of an adder function. The carry propagate is performed on the CLB shown, which also generates the half-sum for the four-bit adder. An

adjacent CLB is responsible for XORing the half-sum with the corresponding carry-out. Thus an adder or counter requires two LCs per bit. Notice that the carry chain requires an initialization stage, which the XC5200 family accomplishes using the carry initialize (CY_INIT) macro and one additional LC.

The XC5200 library contains a set of RPMs and arithmetic functions designed to take advantage of the dedicated carry logic. Using and modifying these macros makes it much easier to implement customized RPMs, freeing the designer from the need to become an expert on architectures.

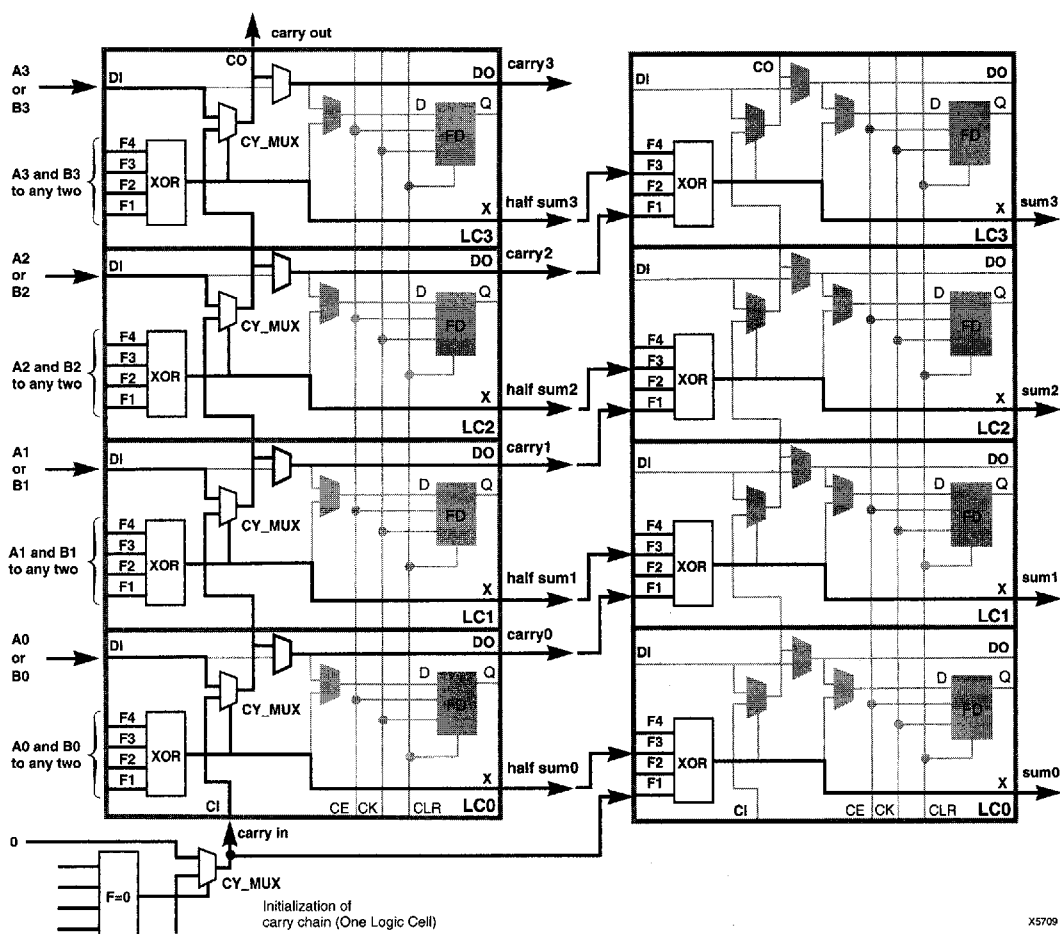

Figure 6: XC5200 CY_MUX Used for Adder Carry Propagate

Cascade Function

Each CY_MUX can be connected to the CY_MUX in the adjacent LC to provide cascadable decode logic. Figure 7 illustrates how the 4-input function generators can be configured to take advantage of these four cascaded CY_MUXes. Note that AND and OR cascading are specific

cases of a general decode. In AND cascading all bits are decoded equal to logic one, while in OR cascading all bits are decoded equal to logic zero. The flexibility of the LUT achieves this result.

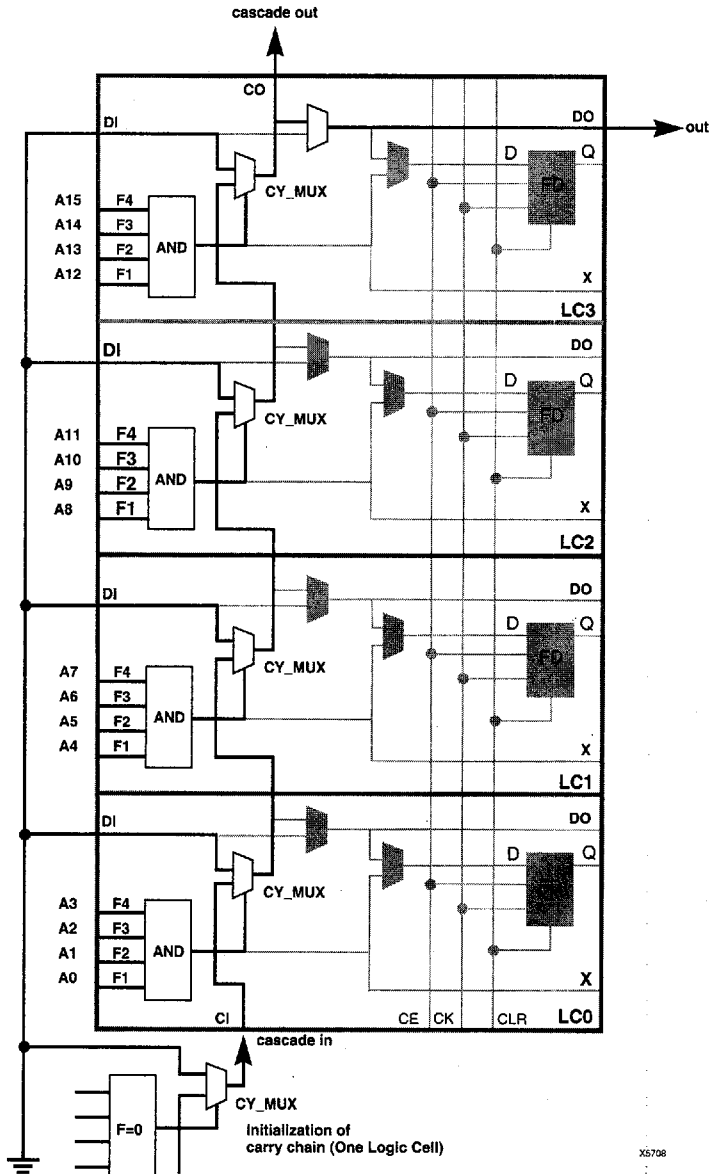

Figure 7: XC5200 CY_MUX Used for Decoder Cascade Logic

3-State Buffers

The XC5200 family has four dedicated TBUFs per CLB. The four buffers are individually configurable through four configuration bits to operate as simple non-inverting buffers or in 3-state mode. When in 3-state mode the CLB's output enable (TS) control signal drives the enable to all four buffers (see Figure 8). Each TBUF can drive up to two horizontal Longlines.

Oscillator

The XC5200 oscillator (OSC52) divides the internal 16-MHz clock or a user clock that is connected to the "C" pin. The user then has the choice of dividing by 4, 16, 64, or 256 for the "OSC1" output and dividing by 2, 8, 32, 128, 1024, 4096, 16384, or 65536 for the "OSC2" output. The division is specified via a "DIVIDEN_BY=x" attribute on the symbol, where n=1 for OSC1, or n=2 for OSC2. The OSC5 macro is used where an internal oscillator is required. The CK_DIV macro is applicable when a user clock input is specified (see Figure 9).

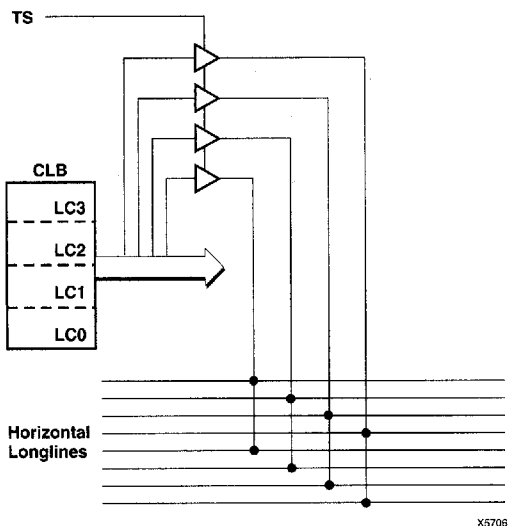

Figure 8: XC5200 3-State Buffer

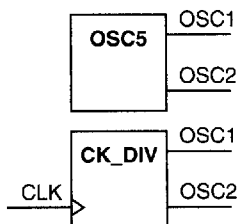

Figure 9: XC5200 Oscillator Macros

Global Reset (GR)

On start-up, all XC5200 internal flip-flops are reset, using a global reset (GR) signal. The user can assign the pin location for the GR signal and use it to reset asynchronously all of the flip-flops in the design without using general routing resources. The user can also assign a positive or negative polarity to GR.

Boundary Scan

XC5200 devices support all the mandatory boundary-scan instructions specified in the IEEE standard 1149.1. A Test Access Port (TAP) and registers are provided that implement the EXTEST, SAMPLE/PRELOAD, and BYPASS instructions. The TAP can also support two USERCODE instructions.

Boundary-scan operation is independent of individual IOB configuration and package type. All IOBs are treated as independently controlled bidirectional pins, including any unbonded IOBs. Retaining the bidirectional test capability after configuration provides flexibility for interconnect testing.

Also, internal signals can be captured during EXTEST by connecting them to unbonded IOBs, or to the unused outputs in IOBs used as unidirectional input pins. This technique partially compensates for the lack of INTEST support.

The public boundary-scan instructions are always available prior to configuration. After configuration, the public instructions and any USERCODE instructions are only available if specified in the design. While SAMPLE and BYPASS are available during configuration, it is recommended that boundary-scan operations not be performed during this transitory period.

In addition to the test instructions outlined above, the boundary-scan circuitry can be used to configure the FPGA device, and to read back the configuration data.

All of the XC4000 boundary-scan modes are supported in the XC5200 family. Three additional outputs for the User Register are provided (Reset, Update, and Shift), representing the decoding of the corresponding state of the boundary-scan internal state machine.

VersaBlock Routing

Local Interconnect Matrix

The GRM connects to the VersaBlock via 24 bidirectional ports (M0-M23). Excluding direct connections, global nets, and 3-statable Longlines, all VersaBlock inputs and outputs connect to the GRM via these 24 ports. Four 3-statable unidirectional signals (TQ0-TQ3) drive out of the VersaBlock directly onto the horizontal Longlines. Two horizontal global nets (GH0 and GH1) and two vertical global nets (GV0 and GV1) connect directly to every CLB clock pin; they can connect to other CLB inputs via the GRM. Each CLB also has four unidirectional direct connects to each of its four neighboring CLBs. These direct connects can also feed directly back to the CLB (see Figure 10).

In addition, each CLB has 16 direct inputs, four direct connections from each of the neighboring CLBs. These direct connections provide high-speed local routing that bypasses the GRM.

The 13 CLB outputs (12 LC outputs plus a V_{cc}/GND signal) connect to the eight VersaBlock outputs via the output multiplexers, which consist of eight fully populated 13-to-1 multiplexers. Of the eight VersaBlock outputs, four signals drive each neighboring CLB directly, and provide a direct feedback path to the input multiplexers. The four remaining multiplexer outputs can drive the GRM through four TBUFs (TQ0-TQ3). All eight multiplexer outputs can connect to the GRM through the bidirectional M0-M23 signals. All eight signals also connect to the input multiplexers and are potential inputs to that CLB.

CLB inputs have several possible sources: the 24 signals from the GRM, 16 direct connections from neighboring VersaBlocks, four signals from global, low-skew buffers (GH0, GH1, GV0, and GV1), and the four signals from the CLB output multiplexers. Unlike the output multiplexers, the input multiplexers are not fully populated; i.e., only a subset of the available signals can be connected to a given CLB input. The flexibility of LUT input swapping and LUT mapping compensates for this limitation. For example, if a 2-input NAND gate is required, it can be mapped into any of the four LUTs, and use any two of the four inputs to the LUT.

Direct Connects

The unidirectional direct-connect segments are connected to the logic input/output pins through the CLB's input and output multiplexer array, and thus bypass the programmable routing matrix altogether. These lines are intended to increase the routing channel utilization where possible, while simultaneously reducing the delay incurred in speed-critical connections.

The direct connects also provide a high-speed path from the edge CLBs to the VersaRing input/output buffers, and thus reduce set-up time, clock-to-out, and combinational propagation delay.

The direct connects are ideal for developing customized RPM cells. Using direct connects improves the macro performance, and leaves the other routing channels intact for improved routing. Direct connects can also route through a CLB using one of the four cell-feedthrough paths.

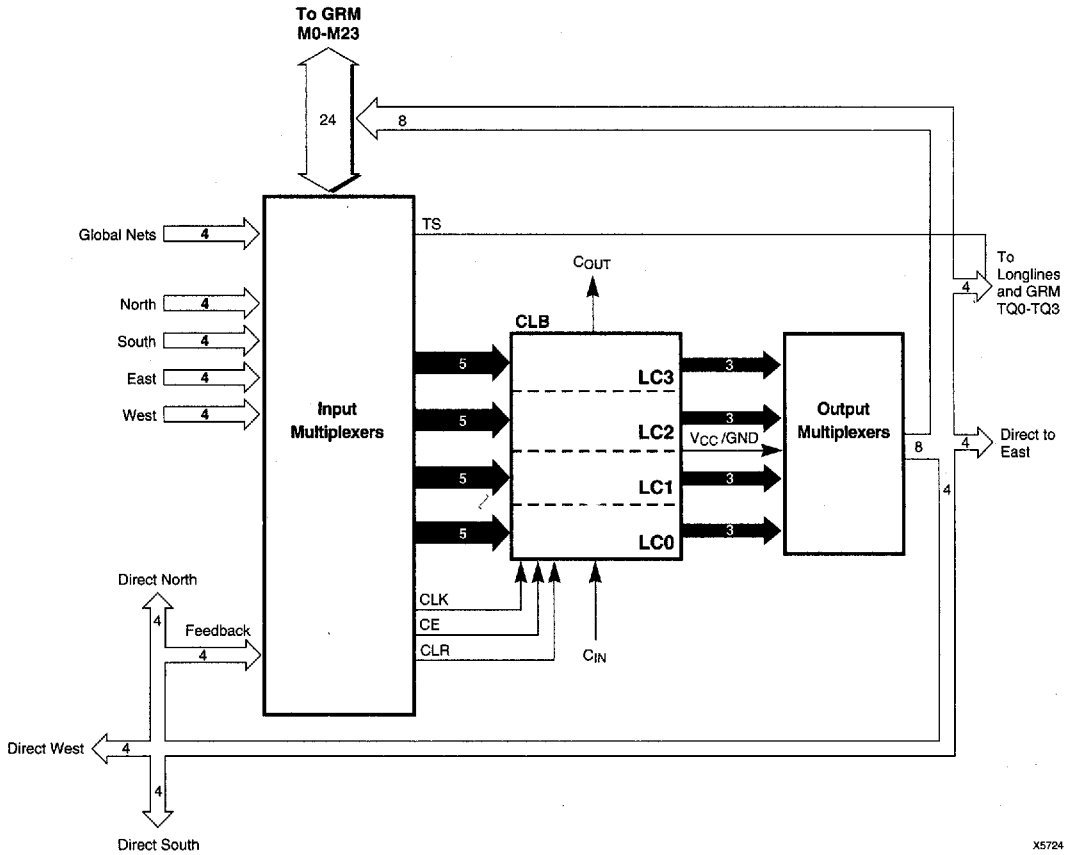

X5724

Figure 10: VersaBlock Details

General Routing Matrix

The General Routing Matrix, shown in Figure 11, provides flexible bidirectional connections to the Local Interconnect Matrix through a hierarchy of different-length metal segments in both the horizontal and vertical directions. A programmable interconnect point (PIP) establishes an electrical connection between two wire segments. The PIP, consisting of a pass transistor switch controlled by a memory element, provides bidirectional (in some cases, unidirectional) connection between two adjoining wires. A collection of PIPs inside the General Routing Matrix and in the Local Interconnect Matrix provides connectivity between various types of metal segments. A hierarchy of PIPs and associated routing segments combine to provide a powerful interconnect hierarchy:

- Forty bidirectional single-length segments per CLB provide ten routing channels to each of the four neighboring CLBs in four directions.
- Sixteen bidirectional double-length segments per CLB provide four routing channels to each of four other (non-neighboring) CLBs in four directions.
- Eight horizontal and eight vertical bidirectional Longline segments span the width and height of the chip, respectively.
- Two low-skew horizontal and vertical unidirectional global-line segments span each row and column of the chip, respectively.

Single- and Double-Length Lines

The single- and double-length bidirectional line segments make up the bulk of the routing channels. The double-length lines hop across every other CLB to reduce the propagation delays in speed-critical nets. Regenerating the signal strength is recommended after traversing three or four such segments. XACTstep place-and-route software automatically connects buffers in the path of the signal as necessary. Single- and double-length lines cannot drive onto Longlines and global lines; Longlines and global lines can, however, drive onto single- and double-length lines. As a general rule, Longline and global-line connections to the programmable routing matrix are unidirectional, with the signal direction from these lines toward the routing matrix.

Longlines

Longlines are used for high-fan-out signals, 3-state busses, low-skew nets, and faraway destinations. Row and column splitter PIPs in the middle of the array effectively double the

total number of Longlines by electrically dividing them into two separated half-lines. The horizontal Longlines are driven by the 3-state buffers in each CLB, and are driven by similar buffers at the periphery of the array from the VersaRing I/O Interface.

Bus-oriented microprocessor designs are accommodated by using horizontal Longlines in conjunction with the 3-state buffers in the CLB and in the VersaRing. Additionally, programmable keeper cells at the periphery can be enabled to retain the last valid logic level on the Longlines when all buffers are in 3-state mode.

Longlines connect to the single-length or double-length lines, or to the logic inside the CLB, through the General Routing Matrix. The only manner in which a Longline can be driven is through the four 3-state buffers; therefore, a Longline-to-Longline or single-line-to-Longline connection through PIPs in the General Routing Matrix is not possible. Again, as a general rule, long- and global-line connections to the General Routing Matrix are unidirectional, with the signal direction from these lines toward the routing matrix.

The XC5200 family has no pull-ups on the ends of the Longlines sourced by TBUFs. Consequently, wired functions (i.e., WAND and WORAND) and wide multiplexing functions requiring pull-ups for undefined states (i.e., bus applications) must be implemented in a different way. In the case of the wired functions, the same functionality can be achieved by taking advantage of the carry/cascade logic described above, implementing a wide logic function in place of the wired function. In the case of 3-state bus applications, the user must insure that all states of the multiplexing function are defined. This process is as simple as adding an additional TBUF to drive the bus High when the previously undefined states are activated.

Global Lines

Global buffers in Xilinx FPGAs are special buffers that drive a dedicated routing network called Global Lines, as shown in Figure 12. This network is intended for high-fan-out clocks or other control signals, to maximize speed and minimize skewing while distributing the signal to many loads.

The XC5200 family has a total of four global buffers (BUFG symbol in the library), each with its own dedicated routing channel. Two are distributed vertically and two horizontally throughout the FPGA.

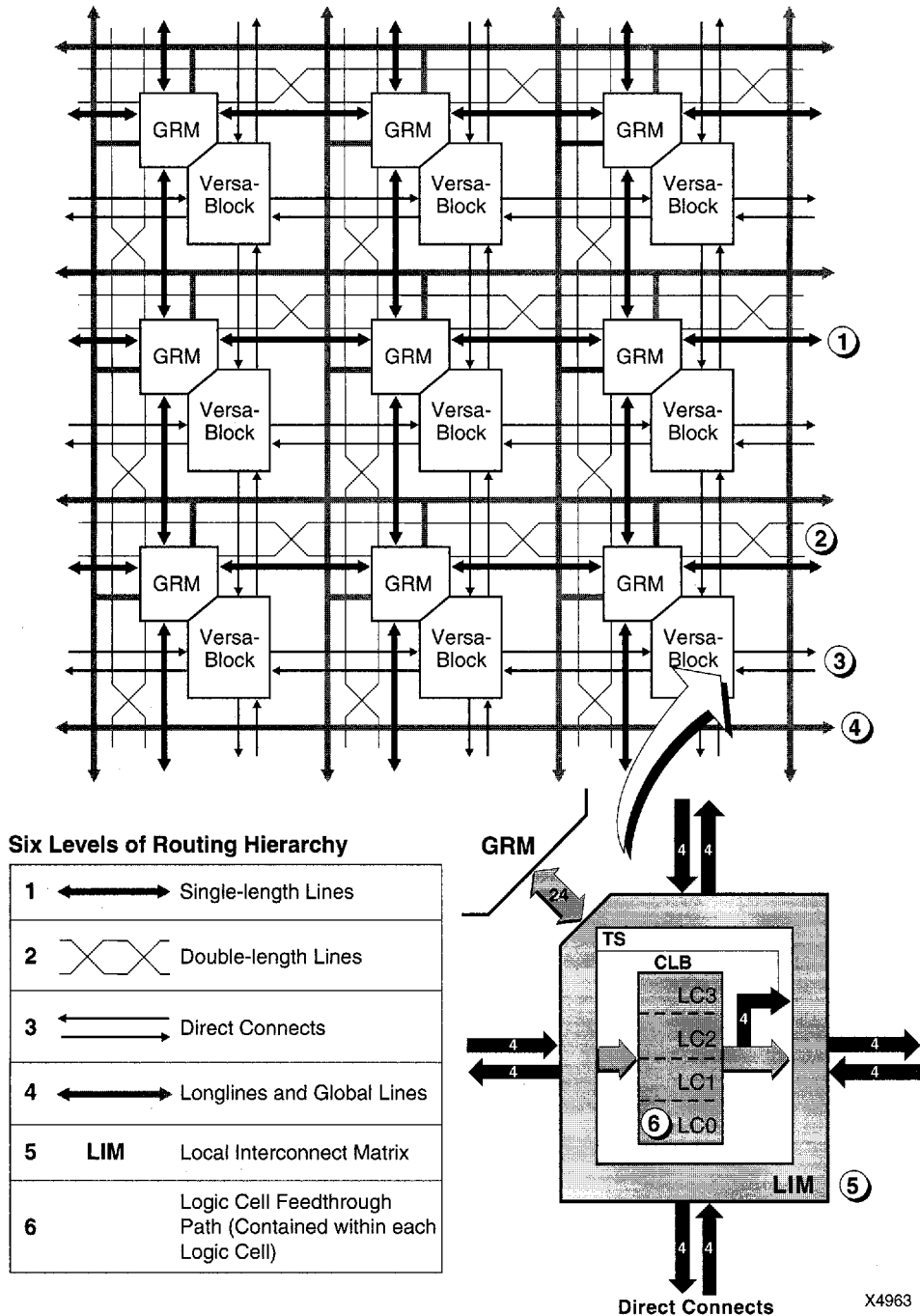

Figure 11: XC5200 Interconnect Structure

The global lines provide direct input only to the CLB clock pins. The global lines also connect to the General Routing Matrix to provide access from these lines to the function generators and other control signals.

Four clock input pads at the corners of the chip, as shown in Figure 12, provide a high-speed, low-skew clock network to each of the four global-line buffers. In addition to the dedicated pad, the global lines can be sourced by internal logic. PIPs from several routing channels within the VersaRing can also be configured to drive the global-line buffers.

VersaRing Input/Output Interface

The VersaRing, shown in Figure 13, is positioned between the core logic and the pad ring; it has all the routing resources of a VersaBlock without the CLB logic. The VersaRing decouples the pad ring's pitch from the core's pitch. Each VersaRing Cell provides up to four pad-cell connections on one side, and connects directly to the CLB ports on the other side. Depending on placement and pad-cell pitch, any number of pad cells to a maximum of four can be connected to a VersaRing cell.

Input/Output Pad

The I/O pad, shown in Figure 14, consists of an input buffer and an output buffer. The output driver is an 8-mA full-rail CMOS buffer with 3-state control. Two slew-rate control modes are supported to minimize bus transients. Both the output buffer and the 3-state control are invertible.

The input buffer has globally selected CMOS and TTL input thresholds. The input buffer is invertible and also provides a programmable delay line to assure reliable chip-to-chip set-up and hold times. Minimum ESD protection is 3 KV using the Human Body Model.

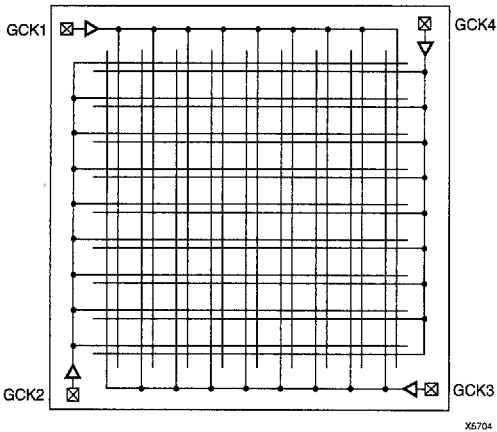

Figure 12: Global Lines

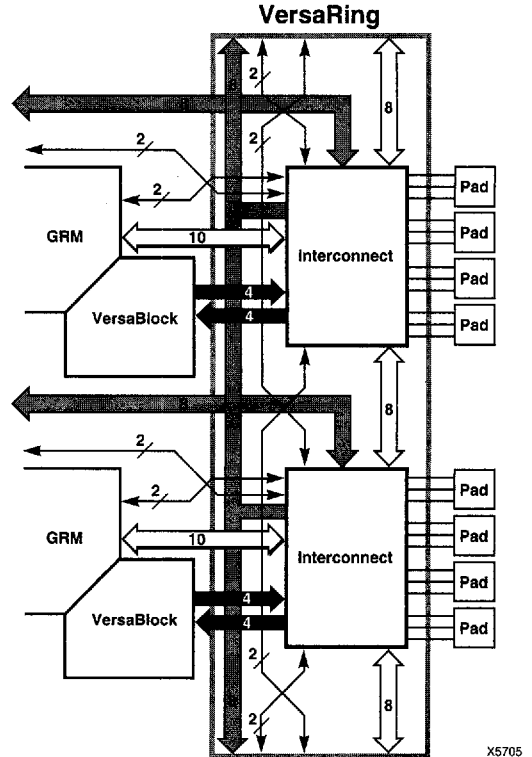

Figure 13: VersaRing I/O Interface

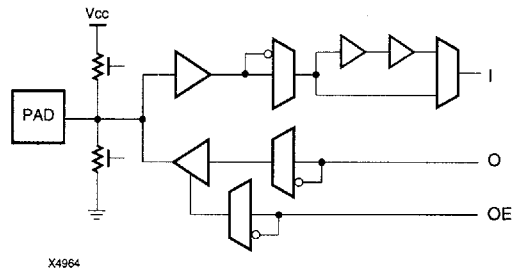

Figure 14: XC5200 I/O Block

Pin Descriptions

Permanently Dedicated Pins

V_{cc}

Eight or more (depending on package type) connections to the nominal +5-V supply voltage. All must be connected.

GND

Eight or more (depending on package type) connections to ground. All must be connected.

CCLK

During configuration, Configuration Clock is an output of the FPGA in master modes or Asynchronous Peripheral mode, but is an input to the FPGA in Slave Serial mode, Synchronous Peripheral mode, and Express mode.

After configuration, CCLK has a weak pull-up resistor and can be selected as Readback Clock.

DONE

This is a bidirectional signal with optional pull-up resistor.

As an output, it indicates the completion of the configuration process. The configuration program determines the exact timing, the clock source for the Low-to-High transition, and enable of the pull-up resistor.

As an input, a Low level on DONE can be configured to delay the global logic initialization or the enabling of outputs.

PROGRAM

This is an active-Low input, held Low during configuration, that forces the FPGA to clear its configuration memory.

When PROGRAM goes High, the FPGA executes a complete clear cycle, before it goes into a WAIT state and releases INIT. After configuration, it has an optional pull-up resistor.

User I/O Pins That Can Have Special Functions

RDY/BUSY

During peripheral modes, this pin indicates when it is appropriate to write another byte of data into the FPGA device. The same status is also available on D7 in Asynchronous Peripheral mode, if a read operation is performed when the device is selected. After configuration, this is a user-programmable I/O pin.

RCLK

During Master Parallel configuration, each change on the A0-17 outputs is preceded by a rising edge on RCLK, a redundant output signal. After configuration, this is a user-programmable I/O pin.

M0, M1, M2

As mode inputs, these pins are sampled before the start of configuration to determine the configuration mode to be used.

After configuration, M0, M1, and M2 become user-programmable I/O.

TDO

If boundary scan is used, this is the Test Data Output.

If boundary scan is not used, this pin becomes user-programmable I/O.

TDI, TCK, TMS

If boundary scan is used, these pins are Test Data In, Test Clock, and Test Mode Select inputs, respectively, coming directly from the pads, bypassing the IOBs. These pins can also be used as inputs to the CLB logic after configuration is completed.

If the boundary scan option is not selected, all boundary scan functions are inhibited once configuration is completed. These pins become user-programmable I/O.

HDC

High During Configuration is driven High until configuration is completed. It is available as a control output indicating that configuration is not yet completed. After configuration, this is a user-programmable I/O pin.

LDC

Low During Configuration is driven Low until configuration completes. It is available as a control output indicating that configuration is not yet completed. After configuration, this is a user-programmable I/O pin.

INIT

Before and during configuration, this is a bidirectional signal. An external pull-up resistor is recommended.

As an active-Low open-drain output, INIT is held Low during the power stabilization and internal clearing of the configuration memory. As an active-Low input, it can be used to hold the FPGA device in the internal WAIT state before the start of configuration. Master-mode devices stay in a WAIT state an additional 50 to 250 μ s after INIT has gone High.

During configuration, a Low on this output indicates that a configuration data error has occurred. After configuration, this is a user-programmable I/O pin.

GCK1 - GCK4

Four Global Inputs each drive a dedicated internal global net with short delay and minimal skew. If not used for this purpose, any of these pins is a user-programmable I/O pin.

CS0, CS1, \overline{WS} , \overline{RS}

These four inputs are used in peripheral modes. The chip is selected when $\overline{CS0}$ is Low and CS1 is High. While the chip is selected, a Low on Write Strobe (\overline{WS}) loads the data present on the D0 - D7 inputs into the internal data buffer; a Low on Read Strobe (\overline{RS}) changes D7 into a status output: High if Ready, Low if Busy, and D0...D6 are active High. \overline{WS} and \overline{RS} should be mutually exclusive, but if both are Low simultaneously, the Write Strobe overrides. After configuration, these are user-programmable I/O pins. In Express mode, CS1 is also used as a serial-enable signal for daisy chaining.

A0 - A17

During Master Parallel mode, these 18 output pins address the configuration EPROM. After configuration, these are user-programmable I/O pins.

D0 - D7

During Master Parallel, peripheral, and Express configuration modes, these eight input pins receive configuration data. After configuration, they are user-programmable I/O pins.

DIN

During Slave Serial or Master Serial configuration modes, this is the serial configuration data input receiving data on the rising edge of CCLK.

During parallel configuration modes, this is the D0 input. After configuration, DIN is a user-programmable I/O pin.

DOUT

During configuration in any non-Express mode, this is the serial configuration data output that can drive the DIN of daisy-chained slave FPGA devices. DOUT data changes on the falling edge of CCLK. After configuration, DOUT is a user-programmable I/O pin.

In Express mode, this is the enable output that can drive CS1 of daisy-chained FPGA devices.

Unrestricted User-Programmable I/O Pins**I/O**

A pin that can be configured to be input and/or output after configuration is completed. Before configuration is completed, these pins have an internal high-impedance pull-up resistor that defines the logical level as High.

Configuration

Configuration is the process of loading design-specific programming data into one or more FPGA devices to define the functional operation of the internal blocks and their interconnections. This is somewhat like loading the command registers of a programmable peripheral chip. Each configuration bit defines the state of a static memory cell that controls either a function LUT bit, a multiplexer input, or an interconnect pass transistor. The XACTstep development system translates the design into a netlist file. It automatically partitions, places, and routes the logic and generates the configuration data in PROM format.

Modes

The XC5200 family has seven modes of configuration, selected by a 3-bit input code applied to the FPGA mode pins (M0, M1, and M2). There are three self-clocking Master modes, two Peripheral modes, a Slave serial mode, and a new high-speed Slave parallel mode called the Express. See Table 4.

Brief descriptions of the seven modes are provided below.

Master Modes

The Master modes use an internal oscillator to generate CCLK for driving potential slave devices, and to generate address and timing for external PROM(s) containing the configuration data. Master Parallel (up or down) modes generate the CCLK signal and PROM addresses, and receive byte parallel data, which is internally serialized into the FPGA data-frame format. The up and down selection generates starting addresses at either zero or 3FFFF, to be compatible with different microprocessor addressing con-

ventions. The Master Serial Mode generates CCLK and receives the configuration data in serial form from a Xilinx serial-configuration PROM.

Peripheral Modes

The two Peripheral modes accept byte-wide data from a bus. A READY/BUSY status is available as a handshake signal. In the asynchronous mode, the internal oscillator generates a CCLK burst signal that serializes the byte-wide data. In the synchronous mode, an externally supplied clock input to CCLK serializes the data.

Slave Serial Mode

In the Slave Serial mode, the FPGA device receives serial-configuration data on the rising edge of CCLK and, after loading its configuration, passes additional data out, resynchronized on the next falling edge of CCLK. Multiple slave devices with identical configurations can be wired with parallel DIN inputs so that the devices can be configured simultaneously.

Daisy Chaining

Multiple devices may be daisy-chained together so that they may be programmed using a single bitstream. The first device in the chain may be set to operate in any mode; all other devices in the chain must be set to operate in Slave Serial mode. Express-mode daisy chains are the only exception: every device in such a chain must be set to operate in Express mode.

All CCLK pins are tied together, and the data chain passes from DOUT to DIN of successive devices along the chain.

Table 4: Configuration Modes

Mode	M2	M1	M0	CCLK	Data
Master Serial	0	0	0	output	Bit-Serial
Slave Serial	1	1	1	input	Bit-Serial
Master Parallel up	1	0	0	output	Byte-Wide, 00000 ↑
Master Parallel down	1	1	0	output	Byte-Wide, 3FFFF ↓
Peripheral Synchronous *	0	1	1	input	Byte-Wide
Peripheral Asynchronous	1	0	1	output	Byte-Wide
Express	0	1	0	input	Byte-Wide
Reserved	0	0	1	—	—

* Peripheral Synchronous can be considered byte-wide Slave Parallel

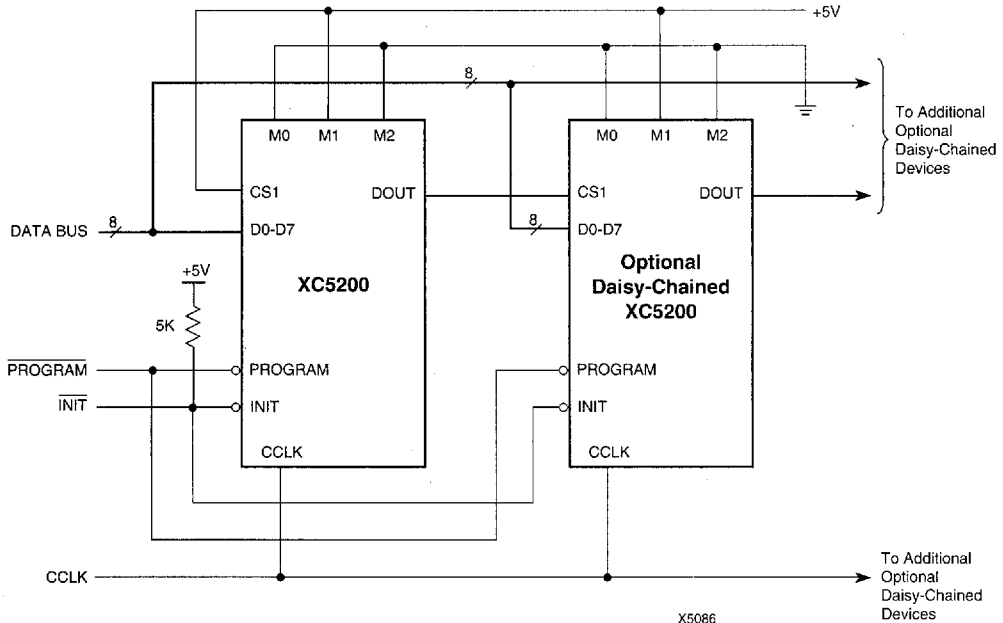

Figure 15: Express Mode

Express Mode

The Express mode (see Figure 15) is similar to the Slave serial mode, except that data is processed one byte per CCLK cycle instead of one bit per CCLK cycle. An external source is used to drive CCLK while byte-wide data is loaded directly into the configuration data shift registers. In this mode the XC5200 family is capable of supporting a CCLK frequency of 10 MHz, which is equivalent to an 80-MHz serial rate, because eight bits of configuration data are being loaded per CCLK cycle. An XC5210 in the Express mode, for instance, can be configured in about 2 ms. The Express mode does not support CRC error checking, but does support constant-field error checking.

In the Express configuration mode, an external signal drives the CCLK input(s) of the FPGA device(s). The first byte of parallel configuration data must be available at the D inputs of the FPGA devices a short set-up time before the second rising CCLK edge. Subsequent data bytes are clocked in on each consecutive rising CCLK edge. See Figure 16.

Bitstream generation currently generates a bitstream sufficient to program in all configuration modes except Express. Extra CCLK cycles are necessary to complete the configuration, since in this mode data is read at a rate of eight bits per CCLK cycle instead of one bit per cycle. Normally the entire start-up sequence requires a number of bits that is equal to the number of CCLK cycles needed. An additional

five CCLKs (equivalent to 40 extra bits) will guarantee completion of configuration, regardless of the start-up options chosen.

The Express mode is supported by the XC5200 and XC4000EX families. It may be used, if XC5200 and XC4000EX devices are daisy-chained.

If the first device is configured in the Express mode, additional devices may be daisy-chained only if every device in the chain is also configured in the Express mode. CCLK pins are tied together and D7-D0 pins are tied together for all devices along the chain. A status signal is passed from DOUT to CS1 of successive devices along the chain. The lead device in the chain has its CS1 input tied High (or floating, since there is an internal pull-up). The status pin DOUT is pulled LOW two internal-oscillator cycles (nominally 1 MHz) after $\overline{\text{INIT}}$ is recognized as High, and remains Low until the device's configuration memory is full. Then DOUT is pulled High to signal the next device in the chain to accept the configuration data on the D7-D0 bus. All devices receive and recognize the six bytes of preamble and length count, irrespective of the level on CS1; but subsequent frame data is accepted only when CS1 is High and the device's configuration memory is not already full.

Format

Table 5 describes the XC5200 configuration data stream. Table 6 describes the internal configuration data structure.

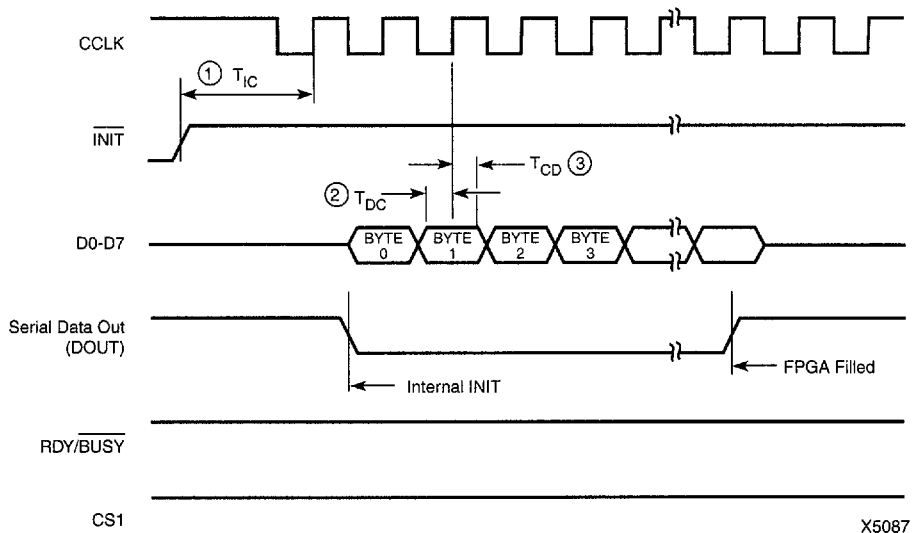

Figure 16: Express Mode Programming Switching Characteristics

	Description	Symbol	Min	Max	Units
CCLK	INIT (High) Setup time required	1 T_{IC}	5		μs
	DIN Setup time required	2 T_{DC}	30		ns
	DIN Hold time required	3 T_{CD}	0		ns
	CCLK High time	T_{CCH}	30		ns
	CCLK Low time	T_{CCL}	30		ns
	CCLK Frequency	F_{CC}		10	MHz

Table 5: XC5200 Bitstream Format

Data Type	Value	Occurrences
Fill Byte	11111111	Once per bit-stream
Preamble	11110010	
Length Counter	COUNT(23:0)	
Fill Byte	11111111	Once per data frame
Start Byte	11111110	
Data Frame *	DATA(N-1:0)	
Cyclic Redundancy Check or Constant Field Check	CRC(3:0) or 0110	
Fill Nibble	1111	
Extend Write Cycle	FFFFFF	
Postamble	11111110	Once per device
Fill Bytes (30)	FFFF...FF	Once per bit-stream
Start-Up Byte	FF	

Table 6: Internal Configuration Data Structure

Device	VersaBlock Array	PROM Size (bits)	Xilinx Serial Prom Needed
XC5202	8 x 8	42,416	XC1765D
XC5204	10 x 12	70,704	XC17128D
XC5206	14 x 14	106,288	XC17128D
XC5210	18 x 18	165,488	XC17256D
XC5215	22 x 22	237,744	XC17256D

Bits per Frame = (34 x number of Rows) + 28 for the top + 28 for the bottom + 4 splitter bits + 8 start bits + 4 error check bits + 4 fill bits * + 24 extended write bits
 = (34 x number of Rows) + 100
 * In the XC5202 (8 x 8), there are 8 fill bits per frame, not 4

Number of Frames = (12 x number of Columns) + 7 for the left edge + 8 for the right edge + 1 splitter bit
 = (12 x number of Columns) + 16

Program Data = (Bits per Frame x Number of Frames) + 48 header bits + 8 postamble bits + 240 fill bits + 8 start-up bits
 = (Bits per Frame x Number of Frames) + 304

PROM Size = Program Data

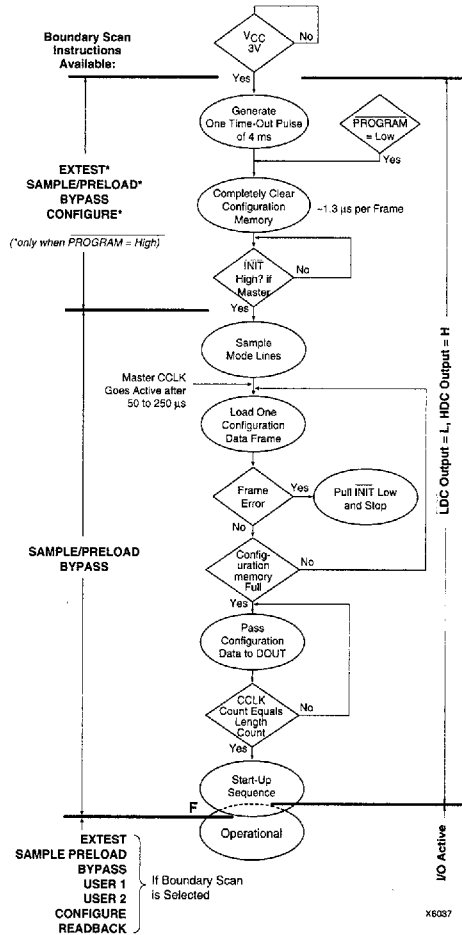

Figure 17: Configuration Sequence

Configuration Sequence

Figure 17 illustrates the XC5200 configuration sequence. This section describes the configuration sequence in detail.

Power-On Time-Out

An internal power-on reset circuit is triggered when power is applied. When V_{CC} reaches the voltage at which portions of the FPGA begin to operate (i.e., performs a write-and-read test of a sample pair of configuration memory bits), the programmable I/O buffers are 3-stated with active high-impedance pull-up resistors. A time-out delay — nominally 4 ms — is initiated to allow the power-supply voltage to stabilize. For correct operation the power supply must reach $V_{CC}(\min)$ by the end of the time-out, and must not dip below it thereafter.

There is no distinction between master and slave modes with regard to the time-out delay. Instead, the \overline{INIT} line is used to ensure that all daisy-chained devices have completed initialization. Since XC2000 devices do not have this signal, extra care must be taken to guarantee proper operation when daisy-chaining them with XC5200 devices. For proper operation with XC3000 devices, the \overline{RESET} signal, which is used in XC3000 to delay configuration, should be connected to \overline{INIT} .

If the time-out delay is insufficient, configuration should be delayed by holding the \overline{INIT} pin Low until the power supply has reached operating levels.

During all three phases — Power-on, Initialization, and Configuration — $DONE$ is held Low; HDC , \overline{LDC} , and \overline{INIT} are active; $DOUT$ is driven; and all I/O buffers are disabled.

Initialization

This phase clears the configuration memory and establishes the configuration mode.

The configuration memory is cleared at the rate of one frame per internal clock cycle (nominally 1 MHz). An open-drain bidirectional signal, \overline{INIT} , is released when the configuration memory is completely cleared. The device then tests for the absence of an external active-low level on \overline{INIT} . The mode lines are sampled two internal clock cycles later (nominally 2 μ s).

The master device waits an additional 32 μ s to 256 μ s (nominally 64-128 μ s) to provide adequate time for all of the slave devices to recognize the release of \overline{INIT} as well. Then the master device enters the Configuration phase.

Configuration

The length counter begins counting immediately upon entry into the configuration state. In slave-mode operation it is important to wait at least two cycles of the internal 1-MHz clock oscillator after \overline{INIT} is recognized before toggling $CCLK$ and feeding the serial bitstream. Configuration will not begin until the internal configuration logic reset is released, which happens two cycles after \overline{INIT} goes High. A master device's configuration is delayed from 32 to 256 μ s to ensure proper operation with any slave devices driven by the master device.

A preamble field at the beginning of the configuration data stream indicates that the next 24 bits represent the length count. The length count equals the total number of configuration bits needed to load the complete configuration data to all daisy-chained devices. Once the preamble and length-count values have been passed through to the next device in the daisy-chain, $DOUT$ is held High to prevent start bits from reaching any daisy-chained devices. After fully configuring itself, the device passes serial data to downstream daisy-chained devices via $DOUT$ until the full length count is reached.

Errors in the configuration bitstream are checked at the end of a frame of data. The device does not check the preamble or length count for errors. In a daisy-chained configuration, configuration data for downstream devices are not checked for errors. If an error is detected after reading a frame, the \overline{ERR} pin (also known as \overline{INIT}) is immediately pulled Low and all configuration activity ceases. However, a master or Peripheral Asynchronous device will continue outputting a configuration clock and incrementing the PROM address indefinitely even though it will never complete configuration. A reprogram or power-on must be applied to remove the device from this state.

Start-Up and Operation

The XC5200 start-up sequence is identical to that of the XC4000 family. Each of these events may occur in any order: (a) $DONE$ is pulled High; and/or (b) user I/Os become active; and/or (c) Internal Reset is deactivated. As a configuration option, the three events may be triggered by a user clock rather than by $CCLK$, or the start-up sequence may be delayed by externally holding the $DONE$ pin Low.

In any mode, the clock cycles of the start-up sequence are not included in the length count. The length of the bitstream is greater than the length count.

Pin Functions During Configuration

CONFIGURATION MODE: <M2:M1:M0>							USER OPERATION
SLAVE <1:1:1>	MASTER-SER <0:0:0>	SYN.PERIPH <0:1:1>	ASYN.PERIPH <1:0:1>	MASTER-HIGH <1:1:0>	MASTER-LOW <1:0:0>	EXPRESS <0:1:0>	
				A16	A16		GCK1-I/O
				A17	A17		I/O
TDI	TDI	TDI	TDI	TDI	TDI	TDI	TDI-I/O
TCK	TCK	TCK	TCK	TCK	TCK	TCK	TCK-I/O
TMS	TMS	TMS	TMS	TMS	TMS	TMS	TMS-I/O
							I/O
M1 (HIGH) (I)	M1 (LOW) (I)	M1 (HIGH) (I)	M1 (LOW) (I)	M1 (HIGH) (I)	M1 (LOW) (I)	M1 (HIGH) (I)	I/O
M0 (HIGH) (I)	M0 (LOW) (I)	M0 (HIGH) (I)	M0 (HIGH) (I)	M0 (LOW) (I)	M0 (LOW) (I)	M0 (LOW) (I)	I/O
M2 (HIGH) (I)	M2 (LOW) (I)	M2 (LOW) (I)	M2 (HIGH) (I)	M2 (HIGH) (I)	M2 (HIGH) (I)	M2 (LOW) (I)	I/O
							GCK2-I/O
HDC (HIGH)	HDC (HIGH)	HDC (HIGH)	HDC (HIGH)	HDC (HIGH)	HDC (HIGH)	HDC (HIGH)	I/O
LDC (LOW)	LDC (LOW)	LDC (LOW)	LDC (LOW)	LDC (LOW)	LDC (LOW)	LDC (LOW)	I/O
INIT-ERROR *	INIT-ERROR *	INIT-ERROR *	INIT-ERROR *	INIT-ERROR *	INIT-ERROR *	INIT-ERROR *	I/O
							I/O
DONE	DONE	DONE	DONE	DONE	DONE	DONE	DONE
PROGRAM (I)	PROGRAM (I)	PROGRAM (I)	PROGRAM (I)	PROGRAM (I)	PROGRAM (I)	PROGRAM (I)	PROGRAM
		DATA 7 (I)	DATA 7 (I)	DATA 7 (I)	DATA 7 (I)	DATA 7 (I)	I/O
							GCK3-I/O
		DATA 6 (I)	DATA 6 (I)	DATA 6 (I)	DATA 6 (I)	DATA 6 (I)	I/O
		DATA 5 (I)	DATA 5 (I)	DATA 5 (I)	DATA 5 (I)	DATA 5 (I)	I/O
			CS0 (I)				I/O
		DATA 4 (I)	DATA 4 (I)	DATA 4 (I)	DATA 4 (I)	DATA 4 (I)	I/O
		DATA 3 (I)	DATA 3 (I)	DATA 3 (I)	DATA 3 (I)	DATA 3 (I)	I/O
			RS (I)				I/O
		DATA 2 (I)	DATA 2 (I)	DATA 2 (I)	DATA 2 (I)	DATA 2 (I)	I/O
		DATA 1 (I)	DATA 1 (I)	DATA 1 (I)	DATA 1 (I)	DATA 1 (I)	I/O
		RDY/BUSY	RDY/BUSY	RCLK	RCLK		I/O
DIN (I)	DIN (I)	DATA 0 (I)	DATA 0 (I)	DATA 0 (I)	DATA 0 (I)	DATA 0 (I)	I/O
DOUT	DOUT	DOUT	DOUT	DOUT	DOUT	DOUT	I/O
CCLK (I)	CCLK (O)	CCLK (I)	CCLK (O)	CCLK (O)	CCLK (O)	CCLK (I)	CCLK (I)
TDO	TDO	TDO	TDO	TDO	TDO	TDO	TDO-I/O
			WS (I)	A0	A0		I/O
				A1	A1		GCK4-I/O
			CS1 (I)	A2	A2	CS1 (I)	I/O
				A3	A3		I/O
				A4	A4		I/O
				A5	A5		I/O
				A6	A6		I/O
				A7	A7		I/O
				A8	A8		I/O
				A9	A9		I/O
				A10	A10		I/O
				A11	A11		I/O
				A12	A12		I/O
				A13	A13		I/O
				A14	A14		I/O
				A15	A15		I/O
							ALL OTHERS

* INIT is an open-drain output during configuration

(I) Represents an input

(O) Represents an output

Before and during configuration, all outputs that are not used for the configuration process are 3-stated with a 50-kΩ to 100-kΩ pull-up resistor.

Configuration Switching Characteristics

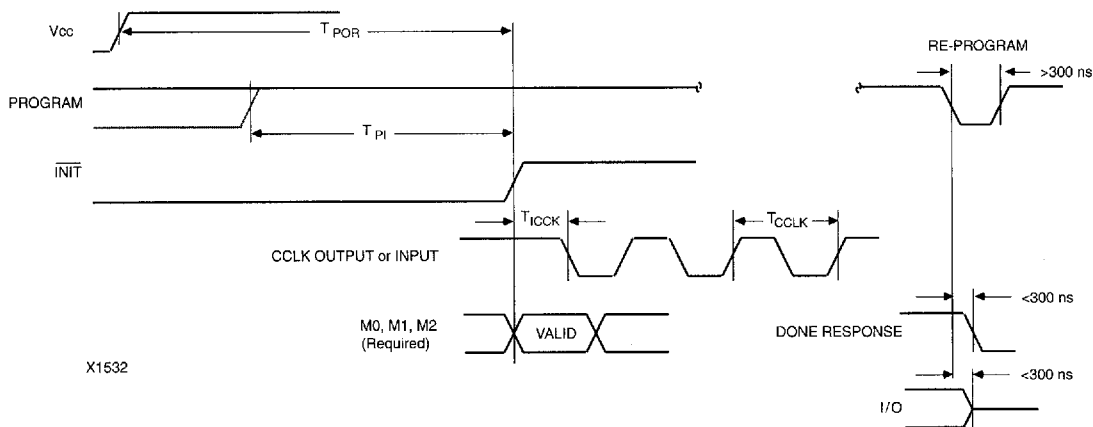

Master Modes

Description	Symbol	Min	Max	Units
Power-On-Reset	T_{POR}	2	15	ms
Program Latency	T_{PI}	6	70	μ s per CLB column
CCLK (output) Delay	T_{ICCK}	40	375	μ s
	T_{CCLK}	640	3000	ns
	T_{CCLK}	100	375	ns

Slave and Peripheral Modes

Description	Symbol	Min	Max	Units
Power-On-Reset	T_{POR}	2	15	ms
Program Latency	T_{PI}	6	70	μ s per CLB column
CCLK (input) Delay (required) period (required)	T_{ICCK}	5		μ s
	T_{CCLK}	100		ns

Note: At power-up, V_{CC} must rise from 2.0 to V_{CC} min in less than 15 ms, otherwise delay configuration using PROGRAM until V_{CC} is valid.

XC5200 Switching Characteristics

Definition of Terms

In the following tables, some specifications may be designated as Advance or Preliminary. These terms are defined as follows:

Advance: Initial estimates based on simulation and/or extrapolation from other speed grades, devices, or device families. Use as estimates, not for production.

Preliminary: Based on preliminary characterization. Further changes are not expected.

Unmarked: Specifications not identified as either Advance or Preliminary are to be considered Final.¹

XC5200 Operating Conditions

Symbol	Description	Min	Max	Units
V_{CC}	Supply voltage relative to GNDCommercial:0°C to 85°C junction	4.75	5.25	V
	Supply voltage relative to GNDIndustrial:-40°C to 100°C junction	4.5	5.5	V
V_{IHT}	High-level input voltage — TTL configuration	2.0	V_{CC}	V
V_{ILT}	Low-level input voltage — TTL configuration	0	0.8	V
V_{IHC}	High-level input voltage — CMOS configuration	70%	100%	V_{CC}
V_{ILC}	Low-level input voltage — CMOS configuration	0	20%	V_{CC}
T_{IN}	Input signal transition time		250	ns

XC5200 DC Characteristics Over Operating Conditions

Symbol	Description	Min	Max	Units
V_{OH}	High-level output voltage @ $I_{OH} = -8.0$ mA, V_{CC} min	3.86		V
V_{OL}	Low-level output voltage @ $I_{OL} = 8.0$ mA, V_{CC} max (Note 1)		0.4	V
I_{CCO}	Quiescent FPGA supply current (Note 1)		15	mA
I_{IL}	Leakage current	-10	+10	μ A
C_{IN}	Input capacitance (sample tested)		15	pF
I_{FIN}	Pad pull-up (when selected) @ $V_{IN} = 0$ V (sample tested)	0.02	0.25	mA

Note: 1. With no output current loads, all package pins at V_{CC} or GND, either TTL or CMOS inputs, and the FPGA configured with a MakeBits tie option.

1. Notwithstanding the definition of the above terms, all specifications are subject to change without notice.

XC5200 Absolute Maximum Ratings

Symbol	Description		Units
V_{CC}	Supply voltage relative to GND	-0.5 to +7.0	V
V_{IN}	Input voltage with respect to GND	-0.5 to $V_{CC} + 0.5$	V
V_{TS}	Voltage applied to 3-state output	-0.5 to $V_{CC} + 0.5$	V
T_{STG}	Storage temperature (ambient)	-65 to +150	°C
T_{SOL}	Maximum soldering temperature (10 s @ 1/16 in. = 1.5 mm)	+260	°C
T_J	Junction temperature in plastic packages	+125	°C
	Junction temperature in ceramic packages	+150	°C

Note: Stresses beyond those listed under Absolute Maximum Ratings may cause permanent damage to the device. These are stress ratings only, and functional operation of the device at these or any other conditions beyond those listed under Recommended Operating Conditions is not implied. Exposure to Absolute Maximum Ratings conditions for extended periods of time may affect device reliability.

XC5200 Global Buffer Switching Characteristic Guidelines

Testing of the switching parameters is modeled after testing methods specified by MIL-M-38510/605. All devices are 100% functionally tested. Since many internal timing parameters cannot be measured directly, they are derived from benchmark timing patterns. The following guidelines reflect worst-case values over the recommended operating conditions. For more detailed, more precise, and more up-to-date timing information, use the values provided by the XACTstep timing calculator and used in the simulator.

Description	Speed Grade		-6	-5	-4	-3	
	Symbol	Device	Max (ns)	Max (ns)	Max (ns)	Max (ns)	
Global Signal Distribution From pad through global buffer, to any clock (CK)	T_{BUFG}	XC5202	9.1	8.5			
		XC5204	9.3	8.7			
		XC5206	9.4	8.8			
		XC5210	9.4	8.8	8.5	8.3	
		XC5215	10.5	9.9			
					PRELIMINARY		ADVANCE

Note: 1. Die-size-dependent parameters are based upon XC5210 characterization. Production specifications will vary with array size.

XC5200 Longline Switching Characteristic Guidelines

Testing of the switching parameters is modeled after testing methods specified by MIL-M-38510/605. All devices are 100% functionally tested. Since many internal timing parameters cannot be measured directly, they are derived from benchmark timing patterns. The following guidelines reflect worst-case values over the recommended operating conditions. For more detailed, more precise, and more up-to-date timing information, use the values provided by the XACTstep timing calculator and used in the simulator.

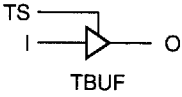
Description	Speed Grade		-6	-5	-4	-3	
	Symbol	Device	Max (ns)	Max (ns)	Max (ns)	Max (ns)	
TBUF driving a Longline  I to Longline, while TS is Low; i.e., buffer is constantly active	T_{IO}	XC5202	6.0	3.8			
		XC5204	6.4	4.1			
		XC5206	6.6	4.2			
		XC5210	6.6	4.2	3.3	3.2	
		XC5215	7.3	4.6			
TS going Low to Longline going from floating High or Low to active Low or High	T_{ON}	XC5202	7.8	5.6			
		XC5204	8.3	5.9			
		XC5206	8.4	6.0			
		XC5210	8.4	6.0	5.0	4.7	
		XC5215	8.9	6.3			
TS going High to TBUF going inactive, not driving Longline	T_{OFF}	XC52xx	3.0	2.8			
					PRELIMINARY		ADVANCE

Note: 1. Die-size-dependent parameters are based upon XC5210 characterization. Production specifications will vary with array size.

XC5200 CLB Switching Characteristic Guidelines

Testing of the switching parameters is modeled after testing methods specified by MIL-M-38510/605. All devices are 100% functionally tested. Since many internal timing parameters cannot be measured directly, they are derived from benchmark timing patterns. The following guidelines reflect worst-case values over the recommended operating conditions. For more detailed, more precise, and more up-to-date timing information, use the values provided by the XACTstep timing calculator and used in the simulator.

Speed Grade		-6		-5		-4		-3	
Description	Symbol	Min (ns)	Max (ns)	Min (ns)	Max (ns)	Min (ns)	Max (ns)	Min (ns)	Max (ns)
Combinatorial Delays									
F inputs to X output	T_{ILO}		5.6		4.6		3.8		3.0
DI inputs to DO output (Logic-Cell Feedthrough)	T_{IDO}		4.3		3.5		2.8		2.2
F inputs via F5_MUX to DO output	T_{IMO}		7.2		5.8		5.0		4.2
Carry Delays									
Incremental delay per bit	T_{CY}		0.7		0.6		0.5		0.5
Carry-in overhead from DI	T_{CYDI}		1.8		1.6		1.5		1.3
Carry-in overhead from F	T_{CYL}		3.7		3.2		2.9		2.3
Carry-out overhead to DO	T_{CYO}		4.0		3.2		2.5		2.0
Sequential Delays									
Clock (CK) to out (Q) (Flip-Flop)	T_{CKO}		5.8		4.9		4.0		3.5
Gate (Latch enable) going active to out (Q)	T_{GO}		9.2		7.4		5.9		4.7
Set-up Time Before Clock (CK)									
F inputs	T_{ICK}	2.3		1.8		1.4		1.0	
F inputs via F5_MUX	T_{MICK}	3.8		3.0		2.5		2.1	
DI input	T_{DICK}	0.8		0.5		0.4		0.3	
CE input	T_{EICK}	1.6		1.2		0.9		0.7	
Hold Times After Clock (CK)									
F inputs	T_{CKI}	0		0		0		0	
F inputs via F5_MUX	T_{CKMI}	0		0		0		0	
DI input	T_{CKDI}	0		0		0		0	
CE input	T_{CKEI}	0		0		0		0	
Clock Widths									
Clock High Time	T_{CH}	6.0		6.0		6.0		6.0	
Clock Low Time	T_{CL}	6.0		6.0		6.0		6.0	
Export Control Max. flip-flop toggle rate (MHz)	F_{TOG}		83		83		83		83
Reset Delays									
Width (High)	$T_{CLR W}$	6.0		6.0		6.0		6.0	
Delay from CLR to Q (Flip-Flop)	T_{CLR}		7.7		6.3		5.1		4.0
Delay from CLR to Q (Latch)	$T_{CLR L}$		6.5		5.2		4.2		3.2
Global Reset Delays (see Note 2)									
Width (High)	$T_{GCLR W}$	6.0		6.0		6.0			6.0
Delay from internal GCLR to Q	T_{GCLR}		14.7		12.1		9.1		8.0
								PRELIMINARY	
								ADVANCE	

- Note:** 1. The CLB K to Q output delay (T_{CKO}) of any CLB, plus the shortest possible interconnect delay, is always longer than the Data In hold-time requirement (T_{CKDI}) of any CLB on the same die.
 2. Timing is based upon the XC5215 device. For other devices, see XACTstep Timing Calculator.

XC5200 Guaranteed Input and Output Parameters (Pin-to-Pin)

All values listed below are tested directly, and guaranteed over the operating conditions. The same parameters can also be derived indirectly from the Global Buffer specifications. The XACTstep delay calculator uses this indirect method, and may overestimate because of worst-case assumptions. When there is a discrepancy between these two methods, the values listed below should be used, and the derived values should be considered conservative overestimates.

		Speed Grade		-6	-5	-4	-3
Description	Symbol	Device	Max (ns)	Max (ns)	Max (ns)	Max (ns)	Max (ns)
Global Clock to Output Pad (fast) 	T_{ICKOF} (Max)	XC5202	16.9	15.1			
		XC5204	17.1	15.3			
		XC5206	17.2	15.4			
		XC5210	17.2	15.4	14.2	13.0	
		XC5215	19.0	17.0			
Global Clock to Output Pad (slew-limited) 	T_{ICKO} (Max)	XC5202	21.4	18.7			
		XC5204	21.6	18.9			
		XC5206	21.7	19.0			
		XC5210	21.7	19.0	17.3	17.0	
		XC5215	24.3	21.2			
Input Set-up Time (no delay) to CLB Flip-Flop 	T_{PSUF} (Min)	XC5202	2.5	1.8			
		XC5204	2.3	1.6			
		XC5206	2.2	1.5			
		XC5210	2.2	1.5	1.2	0.8	
		XC5215	0.5	0			
Input Hold Time (no delay) to CLB Flip-Flop 	T_{PHF} (Min)	XC5202	3.2	2.7			
		XC5204	3.4	2.9			
		XC5206	3.5	3.0			
		XC5210	3.5	3.0	2.8	2.6	
		XC5215	4.4	3.9			
Input Set-up Time (with delay) to CLB Flip-Flop 	T_{PSU} (Min)	XC5202	8.8	7.7			
		XC5204	8.6	7.5			
		XC5206	8.5	7.4			
		XC5210	8.5	7.4	6.0	5.0	
		XC5215	6.8	5.7			
Input Hold Time (with delay) to CLB Flip-Flop 	T_{PH} (Min)	XC52xx	0	0	0	0	
						PRELIMINARY	ADVANCE

- Note:**
1. These measurements assume that the flip-flop has a direct connect to or from the IOB. XACT-Performance can be used to assure that direct connects are used.
 2. When testing outputs (fast or slew-limited), half of the outputs on one side of the device are switching.
 3. Die-size-dependent parameters are based upon XC5210 characterization. Production specifications will vary with array size.

XC5200 IOB Switching Characteristic Guidelines

Testing of the switching parameters is modeled after testing methods specified by MIL-M-38510/605. All devices are 100% functionally tested. Since many internal timing parameters cannot be measured directly, they are derived from benchmark timing patterns. The following guidelines reflect worst-case values over the recommended operating conditions. For more detailed, more precise, and more up-to-date timing information, use the values provided by the XACTstep timing calculator and used in the simulator.

		Speed Grade	-6	-5	-4	-3
Description	Symbol	Max (ns)	Max (ns)	Max (ns)	Max (ns)	Max (ns)
Input						
Propagation Delays from CMOS or TTL Levels						
Pad to I (no delay)	T_{PI}	5.7	5.0	4.8	4.0	
Pad to I (with delay)	T_{PID}	11.4	10.2	10.2	9.4	
Output						
Propagation Delays to CMOS or TTL Levels						
Output (O) to Pad (fast)	T_{OPF}	4.6	4.5	4.5	4.2	
Output (O) to Pad (slew-limited)	T_{OPS}	9.5	8.4	8.0	7.5	
From clock (CK) to output pad (fast), using direct connect between Q and output (O)	T_{OKPOF}	10.1	9.3	8.3	7.1	
From clock (CK) to output pad (slew-limited), using direct connect between Q and output (O)	T_{OKPOS}	14.9	13.1	11.8	11.0	
3-state to Pad active (fast)	T_{TSONF}	5.6	5.2	4.9	4.0	
3-state to Pad active (slew-limited)	T_{TSONS}	10.4	9.0	8.3	7.8	
Internal GTS to Pad active (see Note 3)	T_{GTS}	17.7	15.9	14.7	14.0	
					PRELIMINARY	
					ADVANCE	

- Note:**
1. Timing is measured at pin threshold, with 50-pF external capacitance loads. **Slew-limited** output rise/fall times are approximately two times longer than **fast** output rise/fall times. For the effect of capacitive loads on ground bounce, see "XC4000 Series Technical Information" in "Section 13, Product Technical Information" in the 1996 Xilinx *Programmable Logic Data Book*.
 2. Unused and unbonded IOBs are configured by default as inputs with internal pull-up resistors.
 3. Timing is based upon the XC5210 device. For other devices, see XACTstep Timing Calculator.

XC5200 CLB-to-Pad Diagrams

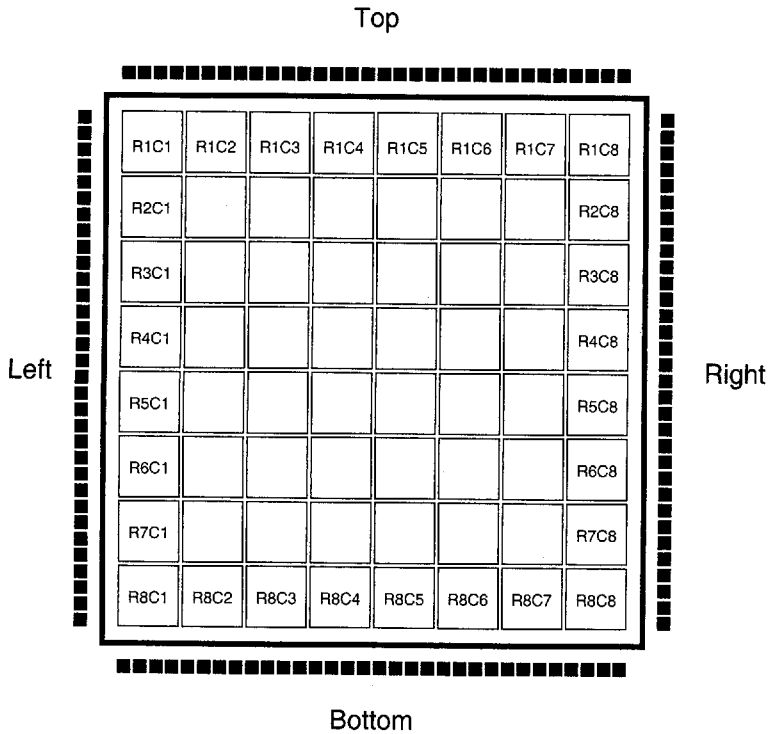

KEY:

■ I/O Pad



CLB, identified by R#C# = row and column numbers

Figure 18: XC5202 CLB-to-Pad Relationship

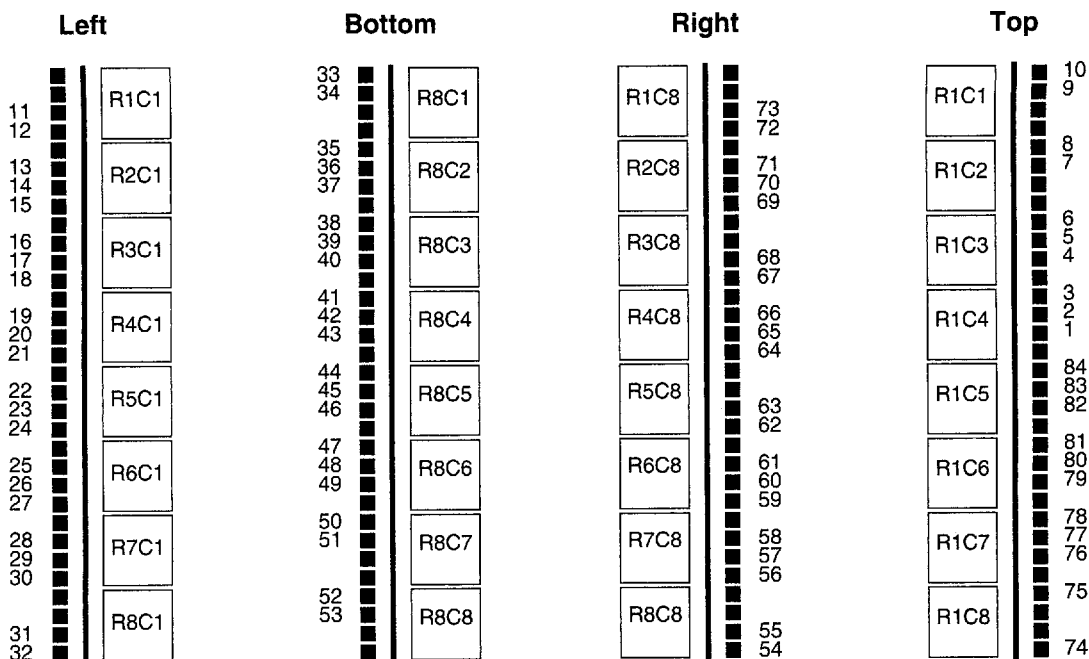

Note: Pad numbers (1, 2, ..., 84) refer to die pads, not external device pins.
See the XC5202 pinout table beginning on page 223.

Figure 19: XC5202 CLB-to-Pad Relationship (Detail)

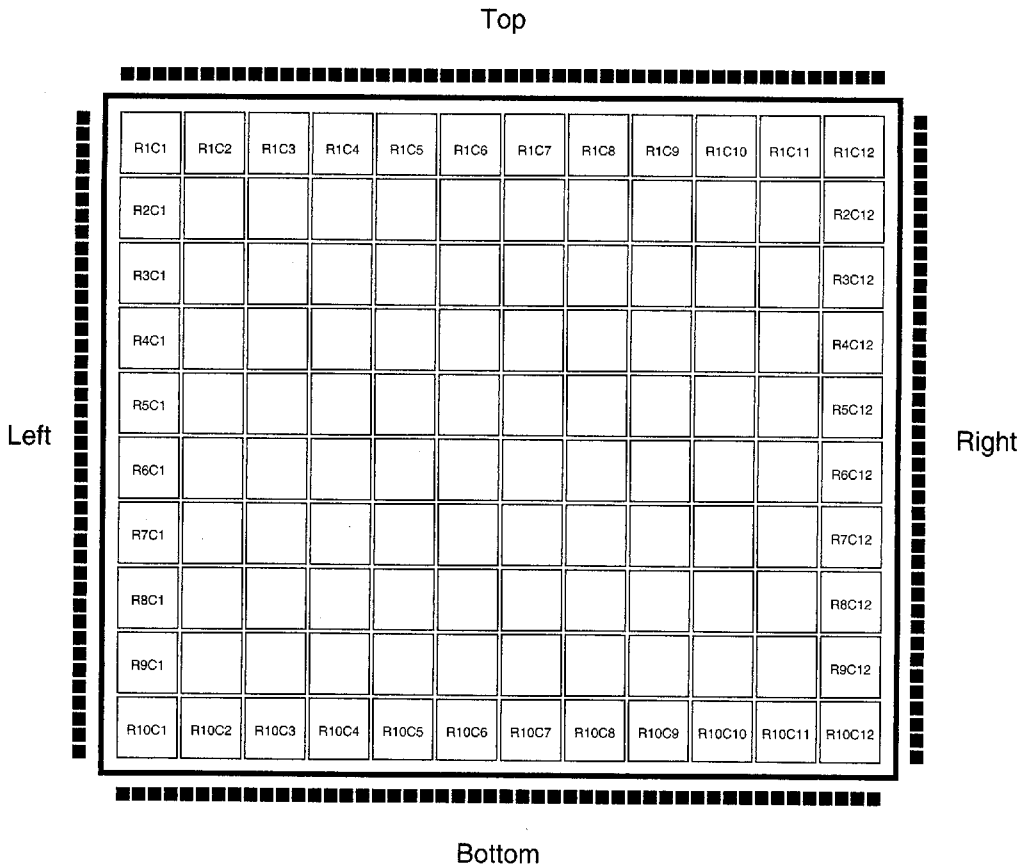

KEY:

■ I/O Pad

R#C#

CLB, identified by R#C# = row and column numbers

Figure 20: XC5204 CLB-to-Pad Relationship

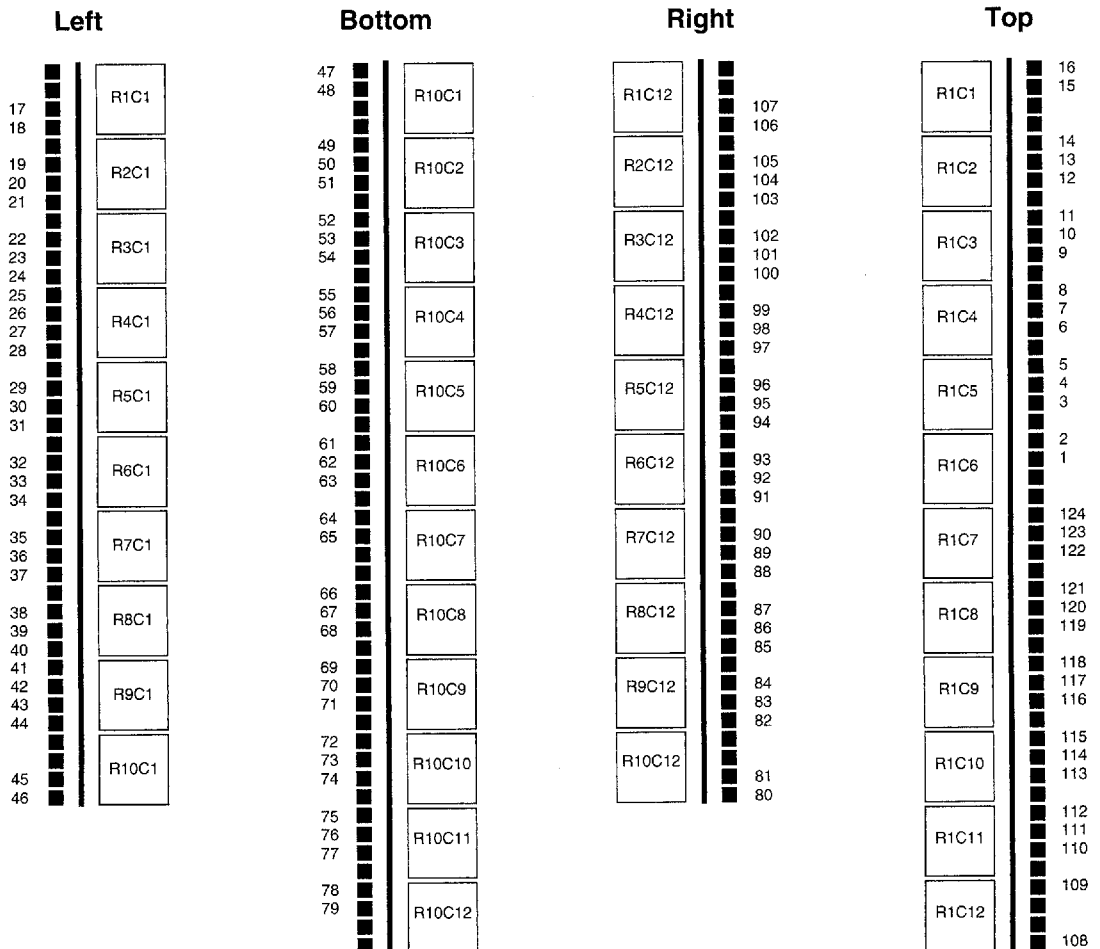

Note: Pad numbers (1, 2, ..., 124) refer to die pads, not external device pins. See the XC5204 pinout table beginning on page 226.

Figure 21: XC5204 CLB-to-Pad Relationship (Detail)

Top

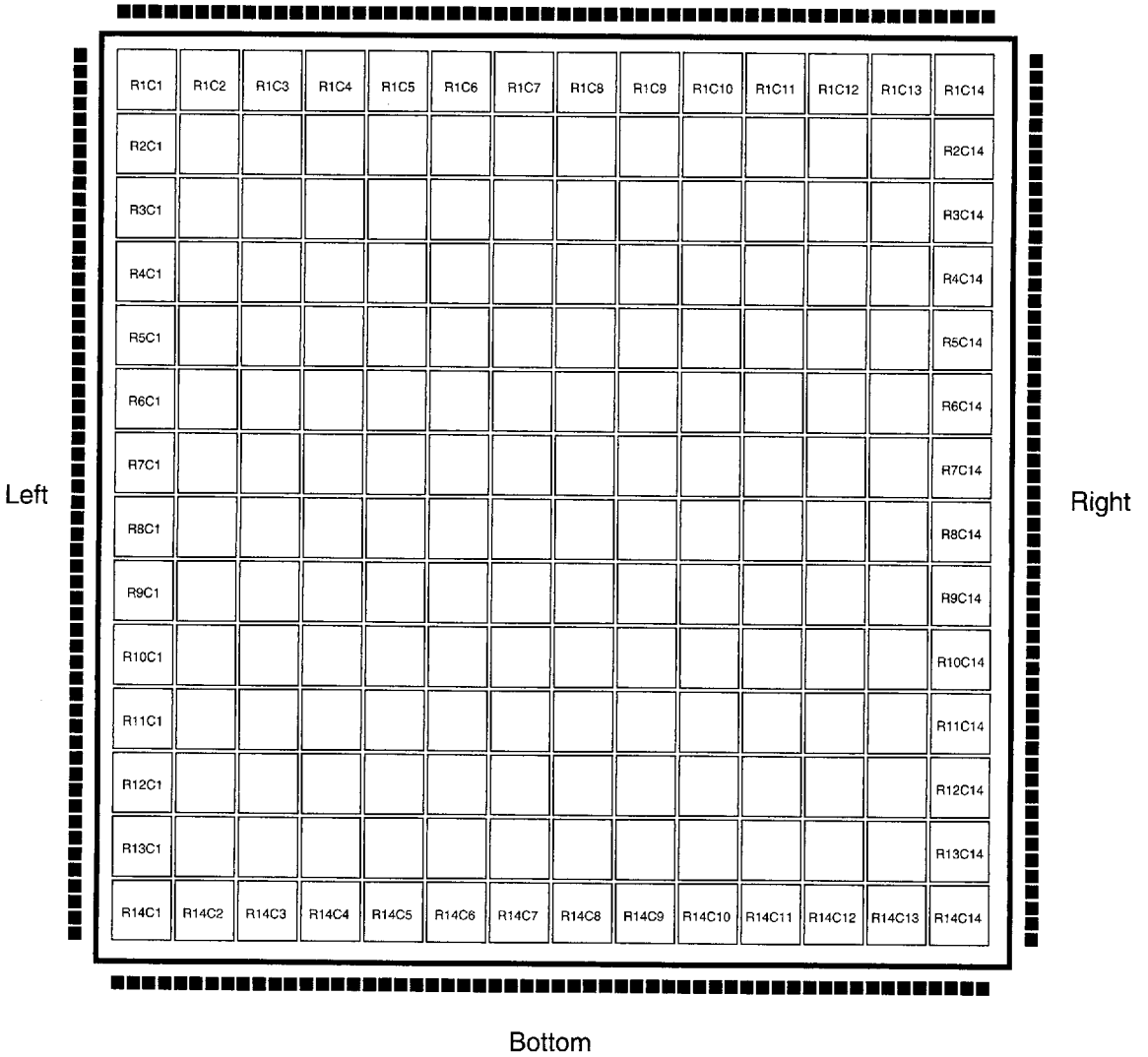

KEY:

■ I/O Pad

R#C#

CLB, identified by R#C# = row and column numbers

Figure 22: XC5206 CLB-to-Pad Relationship

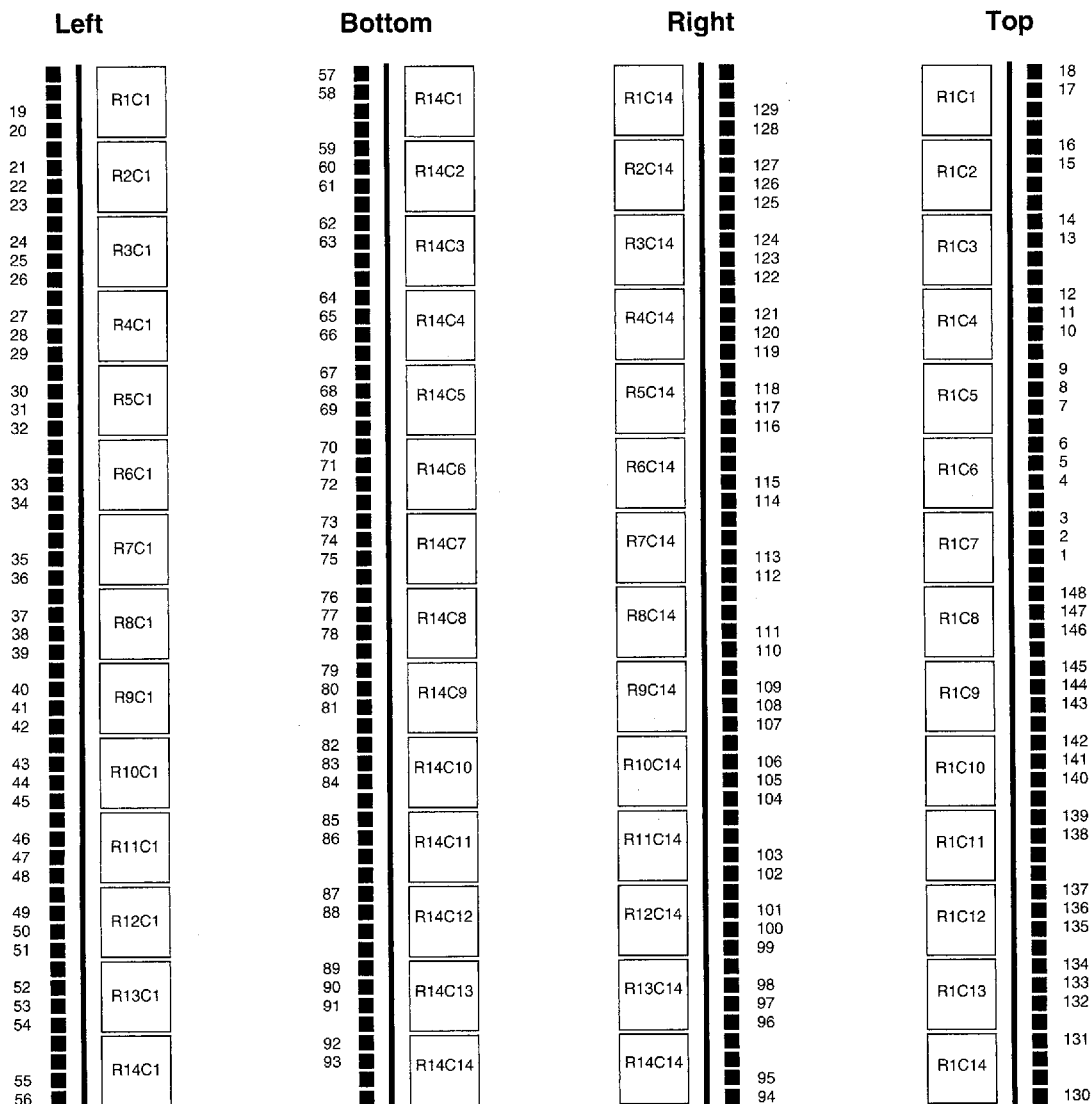

Note: Pad numbers (1, 2, ..., 148) refer to die pads, not external device pins.
See the XC5206 pinout table beginning on page 230.

Figure 23: XC5206 CLB-to-Pad Relationship (Detail)

Top

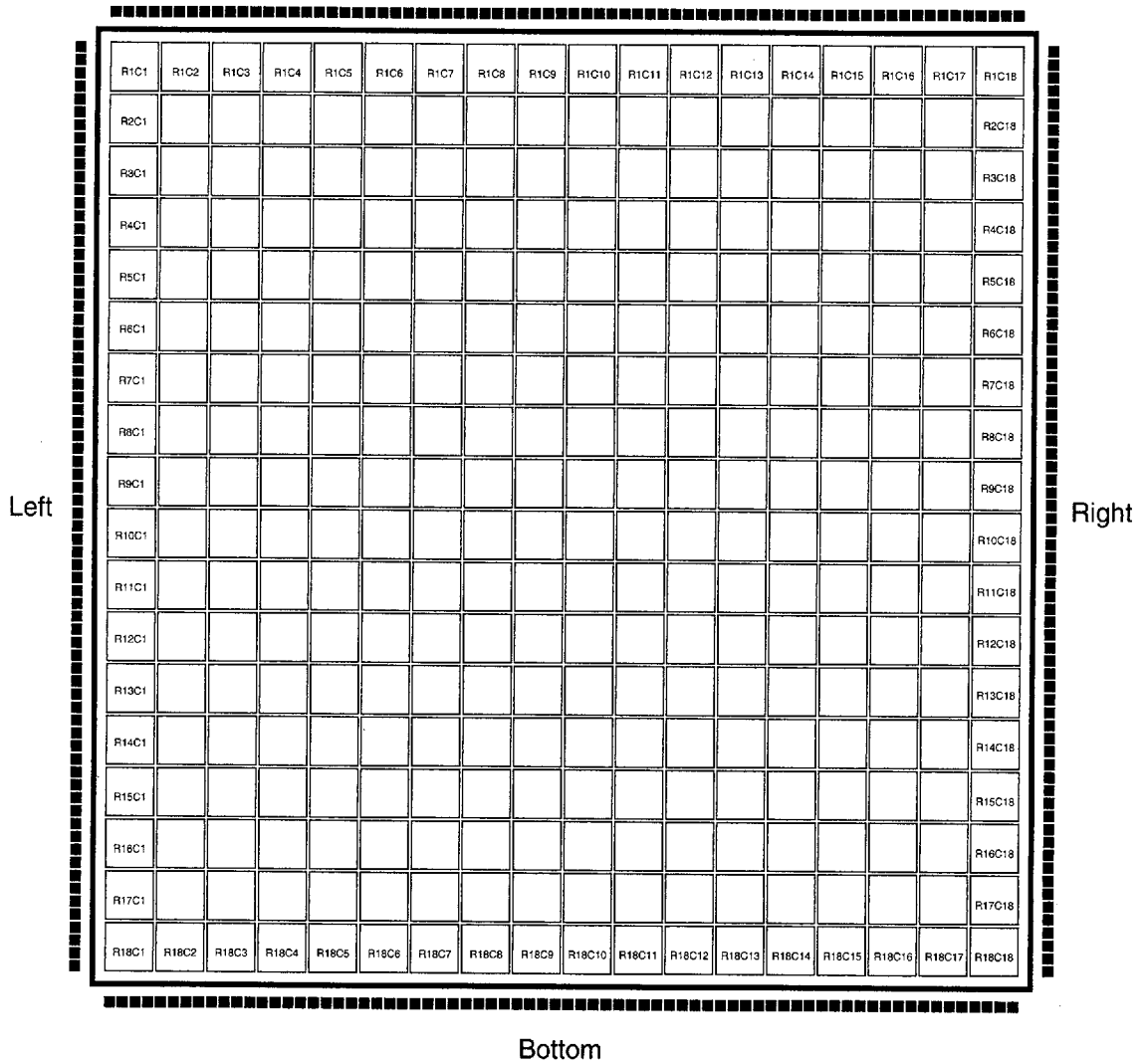

KEY:

■ I/O Pad

R#C# CLB, identified by R#C# = row and column numbers

Figure 24: XC5210 CLB-to-Pad Relationship

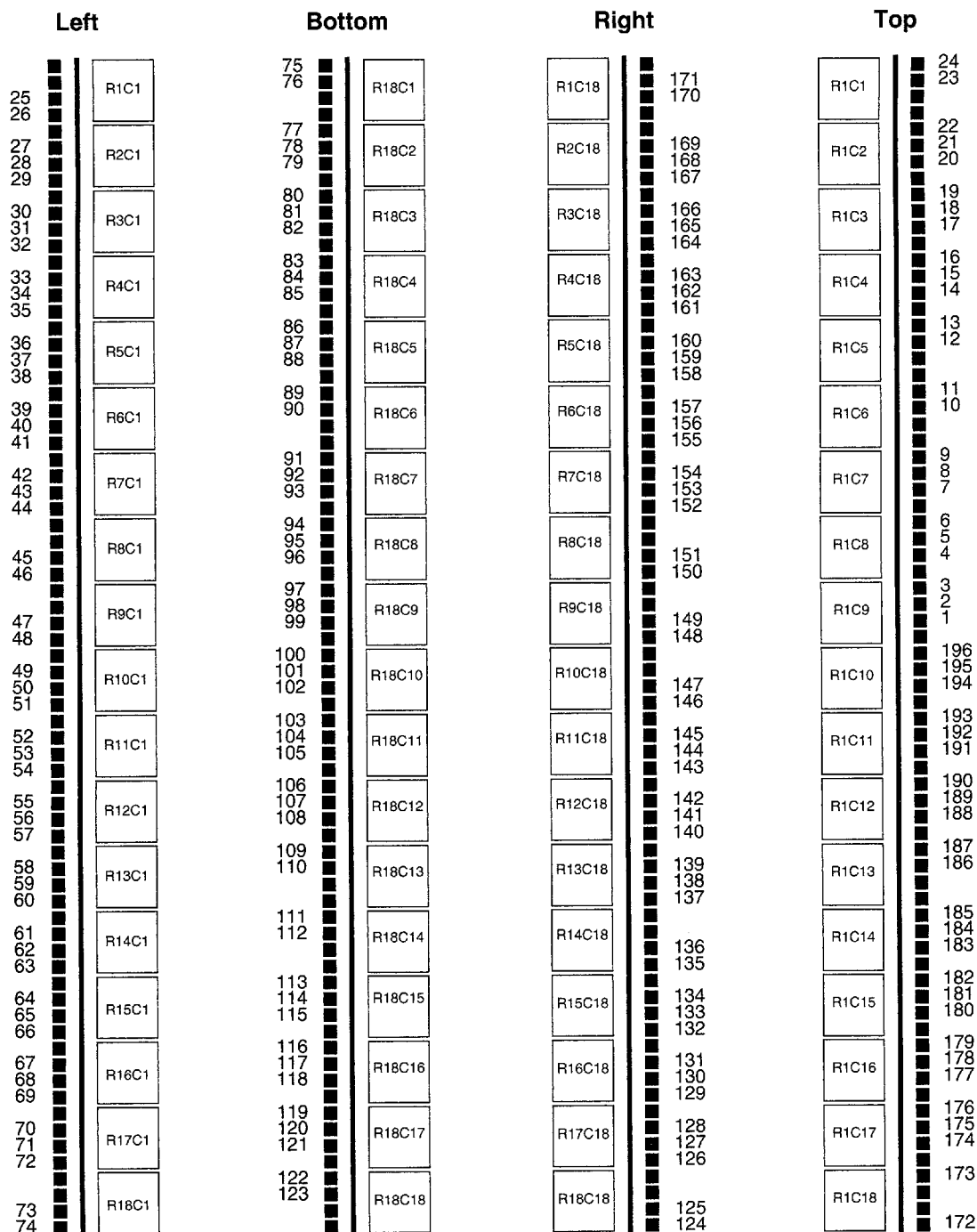

Note: Pad numbers (1, 2, ..., 196) refer to die pads, not external device pins.
See the XC5210 pinout table beginning on page 235.

Figure 25: XC5210 CLB-to-Pad Relationship (Detail)

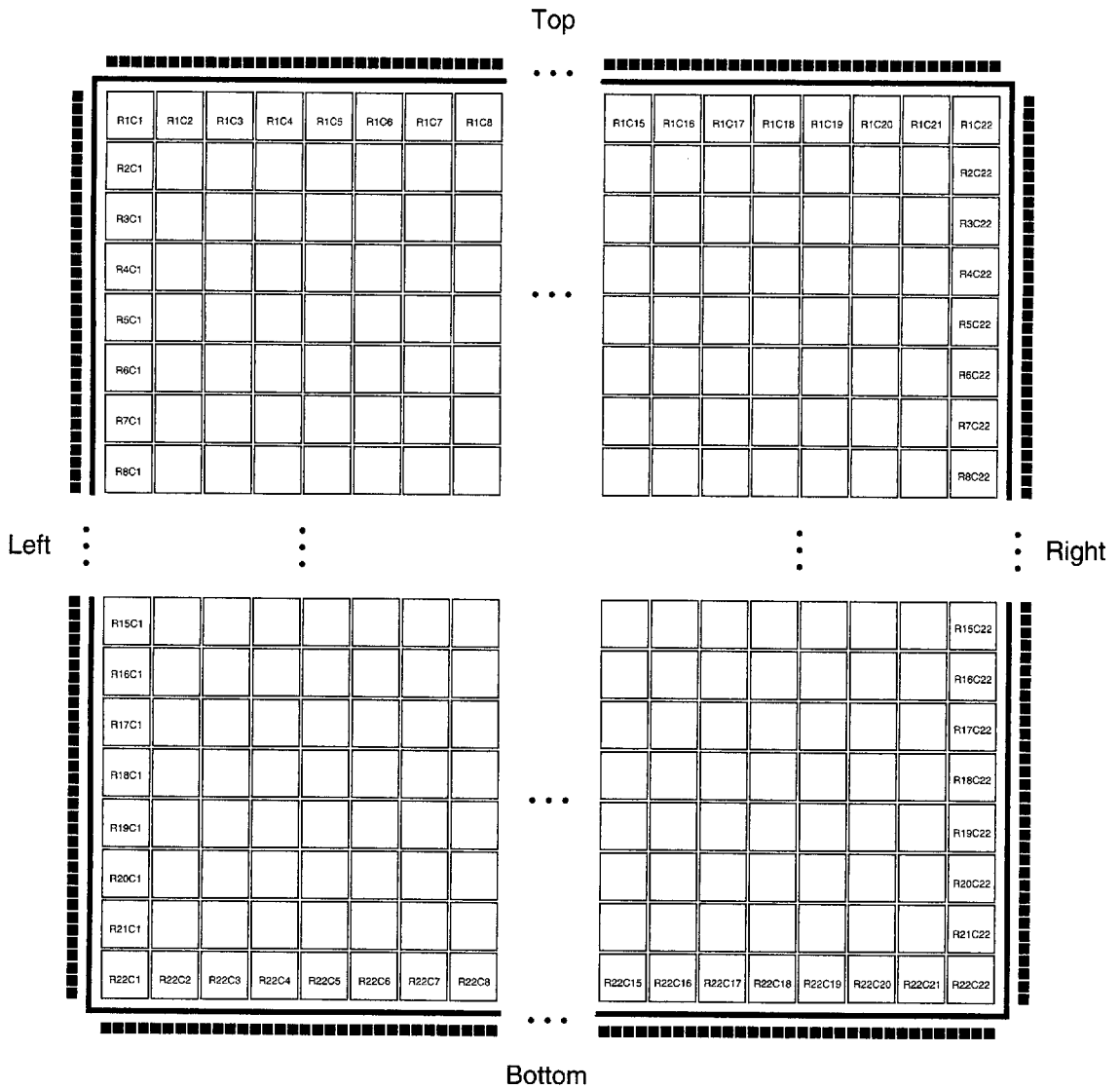

KEY:

■ I/O Pad

□ R#C# CLB, identified by R#C# = row and column numbers

Figure 26: XC5215 CLB-to-Pad Relationship

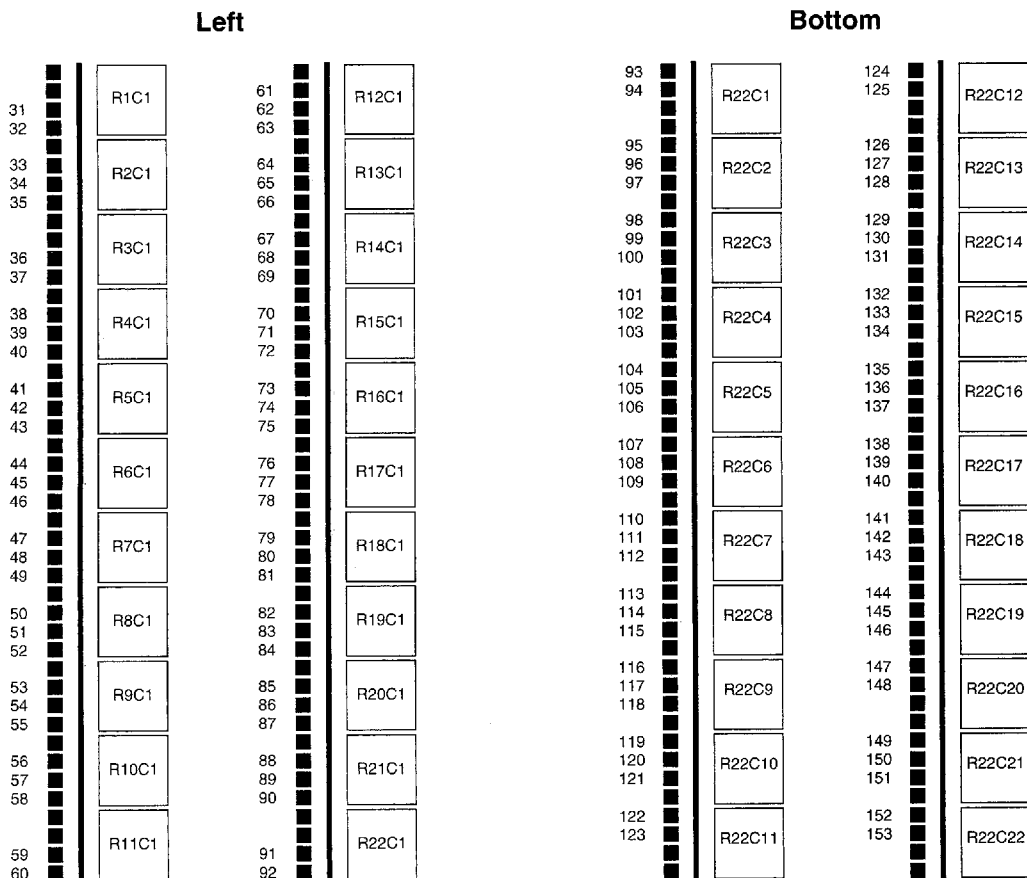

Note: Pad numbers (31, 32, ..., 153) refer to die pads, not external device pins. See the XC5215 pinout table beginning on page 241.

Figure 27: XC5215 CLB-to-Pad Relationship (Left/Bottom Detail)

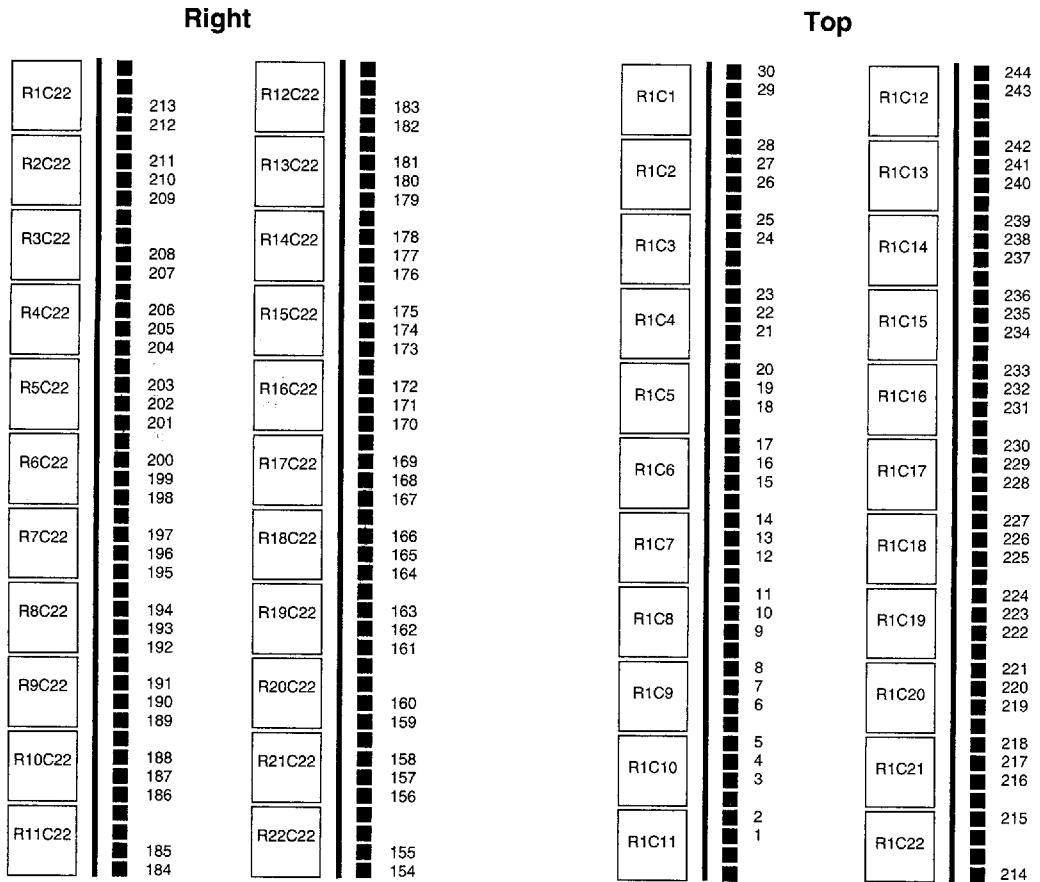

Note: Pad numbers (1, 2, ..., 244) refer to die pads, not external device pins. See the XC5215 pinout table beginning on page 241.

Figure 28: XC5215 CLB-to-Pad Relationship (Right/Top Detail)

Device-Specific Pinout Tables

Pin Locations for XC5202 Devices

Pin	Description †	PC84	PQ100	VQ100	TQ144	PG156	Boundary Scan Order
	VCC	2	92	89	128	H3	-
1.	I/O (A8)	3	93	90	129	H1	51
2.	I/O (A9)	4	94	91	130	G1	54
3.	I/O	-	95	92	131	G2	57
4.	I/O	-	96	93	132	G3	63
5.	I/O (A10)	5	97	94	133	F1	66
6.	I/O (A11)	6	98	95	134	F2	69
	-	-	-	-	135*	-	-
	-	-	-	-	136*	-	-
	GND	-	-	-	137	F3	-
7.	I/O (A12)	7	99	96	138	E3	78
8.	I/O (A13)	8	100	97	139	C1	81
	-	-	-	-	140*	-	-
	-	-	-	-	141*	-	-
9.	I/O (A14)	9	1	98	142	B1	90
10.	I/O (A15)	10	2	99	143	B2	93
	VCC	11	3	100	144	C3	-
	GND	12	4	1	1	C4	-
11.	GCK1 (A16, I/O)	13	5	2	2	B3	102
12.	I/O (A17)	14	6	3	3	A1	105
	-	-	-	-	4*	-	-
	-	-	-	-	5*	-	-
13.	I/O (TDI)	15	7	4	6	B4	111
14.	I/O (TCK)	16	8	5	7	A3	114
	GND	-	-	-	8	C6	-
	-	-	-	-	9*	-	-
	-	-	-	-	10*	-	-
15.	I/O (TMS)	17	9	6	11	A5	117
16.	I/O	18	10	7	12	C7	123
17.	I/O	-	-	-	13	B7	126
18.	I/O	-	11	8	14	A6	129
19.	I/O	19	12	9	15	A7	135
20.	I/O	20	13	10	16	A8	138
	GND	21	14	11	17	C8	-
	VCC	22	15	12	18	B8	-
21.	I/O	23	16	13	19	C9	141
22.	I/O	24	17	14	20	B9	147
23.	I/O	-	18	15	21	A9	150
24.	I/O	-	-	-	22	B10	153
25.	I/O	25	19	16	23	C10	159
26.	I/O	26	20	17	24	A10	162
	-	-	-	-	25*	-	-
	-	-	-	-	26*	-	-
	GND	-	-	-	27	C11	-
27.	I/O	27	21	18	28	B12	165
28.	I/O	-	22	19	29	A13	171
	-	-	-	-	30*	-	-
	-	-	-	-	31*	-	-
29.	I/O	28	23	20	32	B13	174

Pin Locations for XC5202 Devices

Pin	Description †	PC84	PQ100	VQ100	TQ144	PG156	Boundary Scan Order
30.	I/O	29	24	21	33	B14	177
31.	M1 (I/O)	30	25	22	34	A15	186
	GND	31	26	23	35	C13	-
32.	M0 (I/O)	32	27	24	36	A16	189
	VCC	33	28	25	37	C14	-
33.	M2 (I/O)	34	29	26	38	B15	192
34.	GCK2 (I/O)	35	30	27	39	B16	195
35.	I/O (HDC)	36	31	28	40	D14	204
	-	-	-	-	41*	-	-
	-	-	-	-	42*	-	-
36.	I/O	-	32	29	43	E14	207
37.	I/O (LDC)	37	33	30	44	C16	210
	GND	-	-	-	45	F14	-
	-	-	-	-	46*	-	-
	-	-	-	-	47*	-	-
38.	I/O	38	34	31	48	F16	216
39.	I/O	39	35	32	49	G14	219
40.	I/O	-	36	33	50	G15	222
41.	I/O	-	37	34	51	G16	228
42.	I/O	40	38	35	52	H16	231
43.	I/O (ERR, INIT)	41	39	36	53	H15	234
	VCC	42	40	37	54	H14	-
	GND	43	41	38	55	J14	-
44.	I/O	44	42	39	56	J15	240
45.	I/O	45	43	40	57	J16	243
46.	I/O	-	44	41	58	K16	246
47.	I/O	-	45	42	59	K15	252
48.	I/O	46	46	43	60	K14	255
49.	I/O	47	47	44	61	L16	258
	-	-	-	-	62*	-	-
	-	-	-	-	63*	-	-
	GND	-	-	-	64	L14	-
50.	I/O	48	48	45	65	P16	264
51.	I/O	49	49	46	66	M14	267
	-	-	-	-	67*	-	-
	-	-	-	-	68*	-	-
52.	I/O	50	50	47	69	N14	276
53.	I/O	51	51	48	70	R16	279
	GND	52	52	49	71	P14	-
	DONE	53	53	50	72	R15	-
	VCC	54	54	51	73	P13	-
	PROG	55	55	52	74	R14	-
54.	I/O (D7)	56	56	53	75	T16	288
55.	GCK3 (I/O)	57	57	54	76	T15	291
	-	-	-	-	77*	-	-
	-	-	-	-	78*	-	-
56.	I/O (D6)	58	58	55	79	T14	300
57.	I/O	-	59	56	80	T13	303
	GND	-	-	-	81	P11	-
	-	-	-	-	82*	-	-

Pin Locations for XC5202 Devices

Pin	Description †	PC84	PQ100	VQ100	TQ144	PG156	Boundary Scan Order
	-	-	-	-	83*	-	-
58.	I/O (D5)	59	60	57	84	T10	306
59.	I/O ($\overline{CS0}$)	60	61	58	85	P10	312
60.	I/O	-	62	59	86	R10	315
61.	I/O	-	63	60	87	T9	318
62.	I/O (D4)	61	64	61	88	R9	324
63.	I/O	62	65	62	89	P9	327
	VCC	63	66	63	90	R8	-
	GND	64	67	64	91	P8	-
64.	I/O (D3)	65	68	65	92	T8	336
65.	I/O (\overline{RS})	66	69	66	93	T7	339
66.	I/O	-	70	67	94	T6	342
67.	I/O	-	-	-	95	R7	348
68.	I/O (D2)	67	71	68	96	P7	351
69.	I/O	68	72	69	97	T5	360
	-	-	-	-	98*	-	-
	-	-	-	-	99*	-	-
	GND	-	-	-	100	P6	-
70.	I/O (D1)	69	73	70	101	T3	363
71.	I/O (\overline{RCLK} -BUSY/ RDY)	70	74	71	102	P5	366
	-	-	-	-	103*	-	-
	-	-	-	-	104*	-	-
72.	I/O (D0, DIN)	71	75	72	105	P4	372
73.	I/O (DOOUT)	72	76	73	106	T2	375
	CCLK	73	77	74	107	R2	-
	VCC	74	78	75	108	P3	-
74.	I/O (TDO)	75	79	76	109	T1	0
	GND	76	80	77	110	N3	-
75.	I/O (A0, \overline{WS})	77	81	78	111	R1	9
76.	GCK4 (A1, I/O)	78	82	79	112	P2	15
	-	-	-	-	113*	-	-
	-	-	-	-	114*	-	-
77.	I/O (A2, CS1)	79	83	80	115	P1	18
78.	I/O (A3)	80	84	81	116	N1	21
	-	-	-	-	117*	-	-
	GND	-	-	-	118	L3	-
	-	-	-	-	119*	-	-
	-	-	-	-	120*	-	-
79.	I/O (A4)	81	85	82	121	K3	27
80.	I/O (A5)	82	86	83	122	K2	30
81.	I/O	-	87	84	123	K1	33
82.	I/O	-	88	85	124	J1	39
83.	I/O (A6)	83	89	86	125	J2	42
84.	I/O (A7)	84	90	87	126	J3	45
	GND	1	91	88	127	H2	-

Notes: * Indicates unconnected package pins.

† leading numbers refer to bonded pad, shown in Figure 18 or Figure 19.

Boundary Scan Bit 0 = TDO.T

Boundary Scan Bit 1 = TDO.O

Boundary Scan Bit 1056 = BSCAN.UPD

Pin Locations for XC5204 Devices

Pin	Description †	PC84	PQ100	VQ100	TQ144	PG156	PQ160	Boundary Scan Order
	VCC	2	92	89	128	H3	142	-
1.	I/O (A8)	3	93	90	129	H1	143	78
2.	I/O (A9)	4	94	91	130	G1	144	81
3.	I/O	-	95	92	131	G2	145	87
4.	I/O	-	96	93	132	G3	146	90
5.	I/O (A10)	5	97	94	133	F1	147	93
6.	I/O (A11)	6	98	95	134	F2	148	99
7.	I/O	-	-	-	135	E1	149	102
8.	I/O	-	-	-	136	E2	150	105
	GND	-	-	-	137	F3	151	-
9.	I/O	-	-	-	-	D1	152	111
10.	I/O	-	-	-	-	D2	153	114
11.	I/O (A12)	7	99	96	138	E3	154	117
12.	I/O (A13)	8	100	97	139	C1	155	123
13.	I/O	-	-	-	140	C2	156	126
14.	I/O	-	-	-	141	D3	157	129
15.	I/O (A14)	9	1	98	142	B1	158	138
16.	I/O (A15)	10	2	99	143	B2	159	141
	VCC	11	3	100	144	C3	160	-
	GND	12	4	1	1	C4	1	-
17.	GCK1 (A16, I/O)	13	5	2	2	B3	2	150
18.	I/O (A17)	14	6	3	3	A1	3	153
19.	I/O	-	-	-	4	A2	4	159
20.	I/O	-	-	-	5	C5	5	162
21.	I/O (TDI)	15	7	4	6	B4	6	165
22.	I/O (TCK)	16	8	5	7	A3	7	171
	-	-	-	-	-	-	8*	-
	-	-	-	-	-	-	9*	-
	GND	-	-	-	8	C6	10	-
23.	I/O	-	-	-	9	B5	11	174
24.	I/O	-	-	-	10	B6	12	177
25.	I/O (TMS)	17	9	6	11	A5	13	180
26.	I/O	18	10	7	12	C7	14	183
27.	I/O	-	-	-	13	B7	15	186
28.	I/O	-	11	8	14	A6	16	189
29.	I/O	19	12	9	15	A7	17	195
30.	I/O	20	13	10	16	A8	18	198
	GND	21	14	11	17	C8	19	-
	VCC	22	15	12	18	B8	20	-
31.	I/O	23	16	13	19	C9	21	201
32.	I/O	24	17	14	20	B9	22	207
33.	I/O	-	18	15	21	A9	23	210
34.	I/O	-	-	-	22	B10	24	213
35.	I/O	25	19	16	23	C10	25	219
36.	I/O	26	20	17	24	A10	26	222
37.	I/O	-	-	-	25	A11	27	225
38.	I/O	-	-	-	26	B11	28	231
	GND	-	-	-	27	C11	29	-
	-	-	-	-	-	-	30*	-
	-	-	-	-	-	-	31*	-

Pin Locations for XC5204 Devices

Pin	Description †	PC84	PQ100	VQ100	TQ144	PG156	PQ160	Boundary Scan Order
39.	I/O	27	21	18	28	B12	32	234
40.	I/O	-	22	19	29	A13	33	237
41.	I/O	-	-	-	30	A14	34	240
42.	I/O	-	-	-	31	C12	35	243
43.	I/O	28	23	20	32	B13	36	246
44.	I/O	29	24	21	33	B14	37	249
45.	M1 (I/O)	30	25	22	34	A15	38	258
	GND	31	26	23	35	C13	39	-
46.	M0 (I/O)	32	27	24	36	A16	40	261
	VCC	33	28	25	37	C14	41	-
47.	M2 (I/O)	34	29	26	38	B15	42	264
48.	GCK2 (I/O)	35	30	27	39	B16	43	267
49.	I/O (HDC)	36	31	28	40	D14	44	276
50.	I/O	-	-	-	41	C15	45	279
51.	I/O	-	-	-	42	D15	46	282
52.	I/O	-	32	29	43	E14	47	288
53.	I/O (LDC)	37	33	30	44	C16	48	291
54.	I/O	-	-	-	-	E15	49	294
55.	I/O	-	-	-	-	D16	50	300
	GND	-	-	-	45	F14	51	-
56.	I/O	-	-	-	46	F15	52	303
57.	I/O	-	-	-	47	E16	53	306
58.	I/O	38	34	31	48	F16	54	312
59.	I/O	39	35	32	49	G14	55	315
60.	I/O	-	36	33	50	G15	56	318
61.	I/O	-	37	34	51	G16	57	324
62.	I/O	40	38	35	52	H16	58	327
63.	I/O (ERR, INIT)	41	39	36	53	H15	59	330
	VCC	42	40	37	54	H14	60	-
	GND	43	41	38	55	J14	61	-
64.	I/O	44	42	39	56	J15	62	336
65.	I/O	45	43	40	57	J16	63	339
66.	I/O	-	44	41	58	K16	64	348
67.	I/O	-	45	42	59	K15	65	351
68.	I/O	46	46	43	60	K14	66	354
69.	I/O	47	47	44	61	L16	67	360
70.	I/O	-	-	-	62	M16	68	363
71.	I/O	-	-	-	63	L15	69	366
	GND	-	-	-	64	L14	70	-
72.	I/O	-	-	-	-	N16	71	372
73.	I/O	-	-	-	-	M15	72	375
74.	I/O	48	48	45	65	P16	73	378
75.	I/O	49	49	46	66	M14	74	384
76.	I/O	-	-	-	67	N15	75	387
77.	I/O	-	-	-	68	P15	76	390
78.	I/O	50	50	47	69	N14	77	396
79.	I/O	51	51	48	70	R16	78	399
	GND	52	52	49	71	P14	79	-
	DONE	53	53	50	72	R15	80	-
	VCC	54	54	51	73	P13	81	-
	PROG	55	55	52	74	R14	82	-

Pin Locations for XC5204 Devices

Pin	Description †	PC84	PQ100	VQ100	TQ144	PG156	PQ160	Boundary Scan Order
80.	I/O (D7)	56	56	53	75	T16	83	408
81.	GCK3 (I/O)	57	57	54	76	T15	84	411
82.	I/O	-	-	-	77	R13	85	420
83.	I/O	-	-	-	78	P12	86	423
84.	I/O (D6)	58	58	55	79	T14	87	426
85.	I/O	-	59	56	80	T13	88	432
	-	-	-	-	-	-	89*	-
	-	-	-	-	-	-	90*	-
	GND	-	-	-	81	P11	91	-
86.	I/O	-	-	-	82	R11	92	435
87.	I/O	-	-	-	83	T11	93	438
88.	I/O (D5)	59	60	57	84	T10	94	444
89.	I/O (CS0)	60	61	58	85	P10	95	447
90.	I/O	-	62	59	86	R10	96	450
91.	I/O	-	63	60	87	T9	97	456
92.	I/O (D4)	61	64	61	88	R9	98	459
93.	I/O	62	65	62	89	P9	99	462
	VCC	63	66	63	90	R8	100	-
	GND	64	67	64	91	P8	101	-
94.	I/O (D3)	65	68	65	92	T8	102	468
95.	I/O (RS)	66	69	66	93	T7	103	471
96.	I/O	-	70	67	94	T6	104	474
97.	I/O	-	-	-	95	R7	105	480
98.	I/O (D2)	67	71	68	96	P7	106	483
99.	I/O	68	72	69	97	T5	107	486
100.	I/O	-	-	-	98	R6	108	492
101.	I/O	-	-	-	99	T4	109	495
	GND	-	-	-	100	P6	110	-
	-	-	-	-	-	-	111*	-
	-	-	-	-	-	-	112*	-
102.	I/O (D1)	69	73	70	101	T3	113	498
103.	I/O (RCLK-BUSY/RDY)	70	74	71	102	P5	114	504
104.	I/O	-	-	-	103	R4	115	507
105.	I/O	-	-	-	104	R3	116	510
106.	I/O (D0, DIN)	71	75	72	105	P4	117	516
107.	I/O (DOUT)	72	76	73	106	T2	118	519
	CCLK	73	77	74	107	R2	119	-
	VCC	74	78	75	108	P3	120	-
108.	I/O (TDO)	75	79	76	109	T1	121	0
	GND	76	80	77	110	N3	122	-
109.	I/O (A0, WS)	77	81	78	111	R1	123	9
110.	GCK4 (A1, I/O)	78	82	79	112	P2	124	15
111.	I/O	-	-	-	113	N2	125	18
112.	I/O	-	-	-	114	M3	126	21
113.	I/O (A2, CS1)	79	83	80	115	P1	127	27
114.	I/O (A3)	80	84	81	116	N1	128	30
115.	I/O	-	-	-	117	M2	129	33
116.	I/O	-	-	-	-	M1	130	39
	GND	-	-	-	118	L3	131	-
117.	I/O	-	-	-	119	L2	132	42
118.	I/O	-	-	-	120	L1	133	45

Pin Locations for XC5204 Devices

Pin	Description †	PC84	PQ100	VQ100	TQ144	PG156	PQ160	Boundary Scan Order
119.	I/O (A4)	81	85	82	121	K3	134	51
120.	I/O (A5)	82	86	83	122	K2	135	54
	-	-	-	-	-	-	136*	-
121.	I/O	-	87	84	123	K1	137	57
122.	I/O	-	88	85	124	J1	138	63
123.	I/O (A6)	83	89	86	125	J2	139	66
124.	I/O (A7)	84	90	87	126	J3	140	69
	GND	1	91	88	127	H2	141	-

Notes: * Indicates unconnected package pins.

† leading numbers refer to bonded pad, shown in Figure 20 or Figure 21.

Boundary Scan Bit 0 = TDO.T

Boundary Scan Bit 1 = TDO.O

Boundary Scan Bit 1056 = BSCAN.UPD

Pin Locations for XC5206 Devices

Pin	Description †	PC84	PQ100	VQ100	TQ144	PQ160	TQ176	PG191	PQ208	Boundary Scan Order
	VCC	2	92	89	128	142	155	J4	183	-
1.	I/O (A8)	3	93	90	129	143	156	J3	184	87
2.	I/O (A9)	4	94	91	130	144	157	J2	185	90
3.	I/O	-	95	92	131	145	158	J1	186	93
4.	I/O	-	96	93	132	146	159	H1	187	99
5.	I/O	-	-	-	-	-	160	H2	188	102
6.	I/O	-	-	-	-	-	161	H3	189	105
7.	I/O (A10)	5	97	94	133	147	162	G1	190	111
8.	I/O (A11)	6	98	95	134	148	163	G2	191	114
9.	I/O	-	-	-	135	149	164	F1	192	117
10.	I/O	-	-	-	136	150	165	E1	193	123
	GND	-	-	-	137	151	166	G3	194	-
	-	-	-	-	-	-	-	-	195*	-
	-	-	-	-	-	-	167*	-	196*	-
11.	I/O	-	-	-	-	152	168	C1	197	126
12.	I/O	-	-	-	-	153	169	E2	198	129
13.	I/O (A12)	7	99	96	138	154	170	F3	199	138
14.	I/O (A13)	8	100	97	139	155	171	D2	200	141
15.	I/O	-	-	-	140	156	172	B1	201	150
16.	I/O	-	-	-	141	157	173	E3	202	153
17.	I/O (A14)	9	1	98	142	158	174	C2	203	162
18.	I/O (A15)	10	2	99	143	159	175	B2	204	165
	VCC	11	3	100	144	160	176	D3	205	-
	-	-	-	-	-	-	-	-	206*	-
	-	-	-	-	-	-	-	-	207*	-
	-	-	-	-	-	-	-	-	208*	-
	-	-	-	-	-	-	-	-	1*	-
	GND	12	4	1	1	1	1	D4	2	-
	-	-	-	-	-	-	-	-	3*	-
19.	GCK1 (A16, I/O)	13	5	2	2	2	2	C3	4	174
20.	I/O (A17)	14	6	3	3	3	3	C4	5	177
21.	I/O	-	-	-	4	4	4	B3	6	183
22.	I/O	-	-	-	5	5	5	C5	7	186
23.	I/O (TDI)	15	7	4	6	6	6	A2	8	189
24.	I/O (TCK)	16	8	5	7	7	7	B4	9	195
25.	I/O	-	-	-	-	8	8	C6	10	198
26.	I/O	-	-	-	-	9	9	A3	11	201
	-	-	-	-	-	-	-	-	12*	-
	-	-	-	-	-	-	-	-	13*	-
	GND	-	-	-	8	10	10	C7	14	-
27.	I/O	-	-	-	9	11	11	A4	15	207
28.	I/O	-	-	-	10	12	12	A5	16	210
29.	I/O (TMS)	17	9	6	11	13	13	B7	17	213
30.	I/O	18	10	7	12	14	14	A6	18	219
31.	I/O	-	-	-	-	-	15	C8	19	222
32.	I/O	-	-	-	-	-	16	A7	20	225
33.	I/O	-	-	-	13	15	17	B8	21	234
34.	I/O	-	11	8	14	16	18	A8	22	237
35.	I/O	19	12	9	15	17	19	B9	23	246
36.	I/O	20	13	10	16	18	20	C9	24	249

Pin Locations for XC5206 Devices

Pin	Description †	PC84	PQ100	VQ100	TQ144	PQ160	TQ176	PG191	PQ208	Boundary Scan Order
	GND	21	14	11	17	19	21	D9	25	-
	VCC	22	15	12	18	20	22	D10	26	-
37.	I/O	23	16	13	19	21	23	C10	27	255
38.	I/O	24	17	14	20	22	24	B10	28	258
39.	I/O	-	18	15	21	23	25	A9	29	261
40.	I/O	-	-	-	22	24	26	A10	30	267
41.	I/O	-	-	-	-	-	27	A11	31	270
42.	I/O	-	-	-	-	-	28	C11	32	273
43.	I/O	25	19	16	23	25	29	B11	33	279
44.	I/O	26	20	17	24	26	30	A12	34	282
45.	I/O	-	-	-	25	27	31	B12	35	285
46.	I/O	-	-	-	26	28	32	A13	36	291
	GND	-	-	-	27	29	33	C12	37	-
	-	-	-	-	-	-	-	-	38*	-
	-	-	-	-	-	-	-	-	39*	-
47.	I/O	-	-	-	-	30	34	A15	40	294
48.	I/O	-	-	-	-	31	35	C13	41	297
49.	I/O	27	21	18	28	32	36	B14	42	303
50.	I/O	-	22	19	29	33	37	A16	43	306
51.	I/O	-	-	-	30	34	38	B15	44	309
52.	I/O	-	-	-	31	35	39	C14	45	315
53.	I/O	28	23	20	32	36	40	A17	46	318
54.	I/O	29	24	21	33	37	41	B16	47	321
55.	M1 (I/O)	30	25	22	34	38	42	C15	48	330
	GND	31	26	23	35	39	43	D15	49	-
56.	M0 (I/O)	32	27	24	36	40	44	A18	50	333
	-	-	-	-	-	-	-	-	51*	-
	-	-	-	-	-	-	-	-	52*	-
	-	-	-	-	-	-	-	-	53*	-
	-	-	-	-	-	-	-	-	54*	-
	VCC	33	28	25	37	41	45	D16	55	-
57.	M2 (I/O)	34	29	26	38	42	46	C16	56	336
58.	GCK2 (I/O)	35	30	27	39	43	47	B17	57	339
59.	I/O (HDC)	36	31	28	40	44	48	E16	58	348
60.	I/O	-	-	-	41	45	49	C17	59	351
61.	I/O	-	-	-	42	46	50	D17	60	354
62.	I/O	-	32	29	43	47	51	B18	61	360
63.	I/O (LDC)	37	33	30	44	48	52	E17	62	363
64.	I/O	-	-	-	-	49	53	F16	63	372
65.	I/O	-	-	-	-	50	54	C18	64	375
	-	-	-	-	-	-	-	-	65*	-
	-	-	-	-	-	-	-	-	66*	-
	GND	-	-	-	45	51	55	G16	67	-
66.	I/O	-	-	-	46	52	56	E18	68	378
67.	I/O	-	-	-	47	53	57	F18	69	384
68.	I/O	38	34	31	48	54	58	G17	70	387
69.	I/O	39	35	32	49	55	59	G18	71	390
70.	I/O	-	-	-	-	-	60	H16	72	396
71.	I/O	-	-	-	-	-	61	H17	73	399
72.	I/O	-	36	33	50	56	62	H18	74	402
73.	I/O	-	37	34	51	57	63	J18	75	408

Pin Locations for XC5206 Devices

Pin	Description †	PC84	PQ100	VQ100	TQ144	PQ160	TQ176	PG191	PQ208	Boundary Scan Order
74.	I/O	40	38	35	52	58	64	J17	76	411
75.	I/O (ERR, INIT)	41	39	36	53	59	65	J16	77	414
	VCC	42	40	37	54	60	66	J15	78	-
	GND	43	41	38	55	61	67	K15	79	-
76.	I/O	44	42	39	56	62	68	K16	80	420
77.	I/O	45	43	40	57	63	69	K17	81	423
78.	I/O	-	44	41	58	64	70	K18	82	426
79.	I/O	-	45	42	59	65	71	L18	83	432
80.	I/O	-	-	-	-	-	72	L17	84	435
81.	I/O	-	-	-	-	-	73	L16	85	438
82.	I/O	46	46	43	60	66	74	M18	86	444
83.	I/O	47	47	44	61	67	75	M17	87	447
84.	I/O	-	-	-	62	68	76	N18	88	450
85.	I/O	-	-	-	63	69	77	P18	89	456
	GND	-	-	-	64	70	78	M16	90	-
	-	-	-	-	-	-	-	-	91*	-
	-	-	-	-	-	-	-	-	92*	-
86.	I/O	-	-	-	-	71	79	T18	93	459
87.	I/O	-	-	-	-	72	80	P17	94	468
88.	I/O	48	48	45	65	73	81	N16	95	471
89.	I/O	49	49	46	66	74	82	T17	96	480
90.	I/O	-	-	-	67	75	83	R17	97	483
91.	I/O	-	-	-	68	76	84	P16	98	486
92.	I/O	50	50	47	69	77	85	U18	99	492
93.	I/O	51	51	48	70	78	86	T16	100	495
	GND	52	52	49	71	79	87	R16	101	-
	-	-	-	-	-	-	-	-	102*	-
	DONE	53	53	50	72	80	88	U17	103	-
	-	-	-	-	-	-	-	-	104*	-
	-	-	-	-	-	-	-	-	105*	-
	VCC	54	54	51	73	81	89	R15	106	-
	-	-	-	-	-	-	-	-	107*	-
	PROG	55	55	52	74	82	90	V18	108	-
94.	I/O (D7)	56	56	53	75	83	91	T15	109	504
95.	GCK3 (I/O)	57	57	54	76	84	92	U16	110	507
96.	I/O	-	-	-	77	85	93	T14	111	516
97.	I/O	-	-	-	78	86	94	U15	112	519
98.	I/O (D6)	58	58	55	79	87	95	V17	113	522
99.	I/O	-	59	56	80	88	96	V16	114	528
100.	I/O	-	-	-	-	89	97	T13	115	531
101.	I/O	-	-	-	-	90	98	U14	116	534
	-	-	-	-	-	-	-	-	117*	-
	-	-	-	-	-	-	-	-	118*	-
	GND	-	-	-	81	91	99	T12	119	-
102.	I/O	-	-	-	82	92	100	U13	120	540
103.	I/O	-	-	-	83	93	101	V13	121	543
104.	I/O (D5)	59	60	57	84	94	102	U12	122	552
105.	I/O (CS0)	60	61	58	85	95	103	V12	123	555
106.	I/O	-	-	-	-	-	104	T11	124	558
107.	I/O	-	-	-	-	-	105	U11	125	564
108.	I/O	-	62	59	86	96	106	V11	126	567

Pin Locations for XC5206 Devices

Pin	Description †	PC84	PQ100	VQ100	TQ144	PQ160	TQ176	PG191	PQ208	Boundary Scan Order
109.	I/O	-	63	60	87	97	107	V10	127	570
110.	I/O (D4)	61	64	61	88	98	108	U10	128	576
111.	I/O	62	65	62	89	99	109	T10	129	579
	VCC	63	66	63	90	100	110	R10	130	-
	GND	64	67	64	91	101	111	R9	131	-
112.	I/O (D3)	65	68	65	92	102	112	T9	132	588
113.	I/O (\overline{RS})	66	69	66	93	103	113	U9	133	591
114.	I/O	-	70	67	94	104	114	V9	134	600
115.	I/O	-	-	-	95	105	115	V8	135	603
116.	I/O	-	-	-	-	-	116	U8	136	612
117.	I/O	-	-	-	-	-	117	T8	137	615
118.	I/O (D2)	67	71	68	96	106	118	V7	138	618
119.	I/O	68	72	69	97	107	119	U7	139	624
120.	I/O	-	-	-	98	108	120	V6	140	627
121.	I/O	-	-	-	99	109	121	U6	141	630
	GND	-	-	-	100	110	122	T7	142	-
	-	-	-	-	-	-	-	-	143*	-
	-	-	-	-	-	-	-	-	144*	-
122.	I/O	-	-	-	-	111	123	U5	145	636
123.	I/O	-	-	-	-	112	124	T6	146	639
124.	I/O (D1)	69	73	70	101	113	125	V3	147	642
125.	I/O (RCLK-BUSY/RDY)	70	74	71	102	114	126	V2	148	648
126.	I/O	-	-	-	103	115	127	U4	149	651
127.	I/O	-	-	-	104	116	128	T5	150	654
128.	I/O (D0, DIN)	71	75	72	105	117	129	U3	151	660
129.	I/O (DOUT)	72	76	73	106	118	130	T4	152	663
	CCLK	73	77	74	107	119	131	V1	153	-
	VCC	74	78	75	108	120	132	R4	154	-
	-	-	-	-	-	-	-	-	155*	-
	-	-	-	-	-	-	-	-	156*	-
	-	-	-	-	-	-	-	-	157*	-
	-	-	-	-	-	-	-	-	158*	-
130.	I/O (TDO)	75	79	76	109	121	133	U2	159	-
	GND	76	80	77	110	122	134	R3	160	-
131.	I/O (A0, \overline{WS})	77	81	78	111	123	135	T3	161	9
132.	GCK4 (A1, I/O)	78	82	79	112	124	136	U1	162	15
133.	I/O	-	-	-	113	125	137	P3	163	18
134.	I/O	-	-	-	114	126	138	R2	164	21
135.	I/O (A2, CS1)	79	83	80	115	127	139	T2	165	27
136.	I/O (A3)	80	84	81	116	128	140	N3	166	30
137.	I/O	-	-	-	117	129	141	P2	167	33
138.	I/O	-	-	-	-	130	142	T1	168	42
	-	-	-	-	-	-	-	-	169*	-
	-	-	-	-	-	-	-	-	170*	-
	GND	-	-	-	118	131	143	M3	171	-
139.	I/O	-	-	-	119	132	144	P1	172	45
140.	I/O	-	-	-	120	133	145	N1	173	51
141.	I/O (A4)	81	85	82	121	134	146	M2	174	54
142.	I/O (A5)	82	86	83	122	135	147	M1	175	57
143.	I/O	-	-	-	-	-	148	L3	176	63

Pin Locations for XC5206 Devices

Pin	Description †	PC84	PQ100	VQ100	TQ144	PQ160	TQ176	PG191	PQ208	Boundary Scan Order
144.	I/O	-	-	-	-	136	149	L2	177	66
145.	I/O	-	87	84	123	137	150	L1	178	69
146.	I/O	-	88	85	124	138	151	K1	179	75
147.	I/O (A6)	83	89	86	125	139	152	K2	180	78
148.	I/O (A7)	84	90	87	126	140	153	K3	181	81
	GND	1	91	88	127	141	154	K4	182	-

Notes: * Indicates unconnected package pins.

† leading numbers refer to bonded pad, shown in Figure 22 or Figure 23.

Boundary Scan Bit 0 = TDO.T

Boundary Scan Bit 1 = TDO.O

Boundary Scan Bit 1056 = BSCAN.UPD

Pin Locations for XC5210 Devices

Pin	Description †	PC84	TQ144	PQ160	TQ176	PQ208	PG223	BG225	PQ240	Boundary Scan Order
	VCC	2	128	142	155	183	J4	VCC**	212	-
1.	I/O (A8)	3	129	143	156	184	J3	E8	213	111
2.	I/O (A9)	4	130	144	157	185	J2	B7	214	114
3.	I/O	-	131	145	158	186	J1	A7	215	117
4.	I/O	-	132	146	159	187	H1	C7	216	123
5.	I/O	-	-	-	160	188	H2	D7	217	126
6.	I/O	-	-	-	161	189	H3	E7	218	129
	-	-	-	-	-	-	-	-	219*	-
7.	I/O (A10)	5	133	147	162	190	G1	A6	220	135
8.	I/O (A11)	6	134	148	163	191	G2	B6	221	138
	VCC	-	-	-	-	-	-	VCC**	222	-
9.	I/O	-	-	-	-	-	H4	C6	223	141
10.	I/O	-	-	-	-	-	G4	F7	224	150
11.	I/O	-	135	149	164	192	F1	A5	225	153
12.	I/O	-	136	150	165	193	E1	B5	226	162
	GND	-	137	151	166	194	G3	GND**	227	-
13.	I/O	-	-	-	-	195	F2	D6	228	165
14.	I/O	-	-	-	167	196	D1	C5	229	171
15.	I/O	-	-	152	168	197	C1	A4	230	174
16.	I/O	-	-	153	169	198	E2	E6	231	177
17.	I/O (A12)	7	138	154	170	199	F3	B4	232	183
18.	I/O (A13)	8	139	155	171	200	D2	D5	233	186
19.	I/O	-	-	-	-	-	F4	A3	234	189
20.	I/O	-	-	-	-	-	E4	C4	235	195
21.	I/O	-	140	156	172	201	B1	B3	236	198
22.	I/O	-	141	157	173	202	E3	F6	237	201
23.	I/O (A14)	9	142	158	174	203	C2	A2	238	210
24.	I/O (A15)	10	143	159	175	204	B2	C3	239	213
	VCC	11	144	160	176	205	D3	VCC**	240	-
	-	-	-	-	-	206*	-	-	-	-
	-	-	-	-	-	207*	-	-	-	-
	-	-	-	-	-	208*	-	-	-	-
	-	-	-	-	-	1*	-	-	-	-
	GND	12	1	1	1	2	D4	GND**	1	-
	-	-	-	-	-	3*	-	-	-	-
25.	GCK1 (A16, I/O)	13	2	2	2	4	C3	D4	2	222
26.	I/O (A17)	14	3	3	3	5	C4	B1	3	225
27.	I/O	-	4	4	4	6	B3	C2	4	231
28.	I/O	-	5	5	5	7	C5	E5	5	234
29.	I/O (TDI)	15	6	6	6	8	A2	D3	6	237
30.	I/O (TCK)	16	7	7	7	9	B4	C1	7	243
31.	I/O	-	-	8	8	10	C6	D2	8	246
32.	I/O	-	-	9	9	11	A3	G6	9	249
33.	I/O	-	-	-	-	12	B5	E4	10	255
34.	I/O	-	-	-	-	13	B6	D1	11	258
35.	I/O	-	-	-	-	-	D5	E3	12	261
36.	I/O	-	-	-	-	-	D6	E2	13	267
	GND	-	8	10	10	14	C7	GND**	14	-
37.	I/O	-	9	11	11	15	A4	F5	15	270

Pin Locations for XC5210 Devices

Pin	Description †	PC84	TQ144	PQ160	TQ176	PQ208	PG223	BG225	PQ240	Boundary Scan Order
38.	I/O	-	10	12	12	16	A5	E1	16	273
39.	I/O (TMS)	17	11	13	13	17	B7	F4	17	279
40.	I/O	18	12	14	14	18	A6	F3	18	282
	VCC	-	-	-	-	-	-	VCC**	19	-
41.	I/O	-	-	-	-	-	D7	F2	20	285
42.	I/O	-	-	-	-	-	D8	F1	21	291
	-	-	-	-	-	-	-	-	22*	-
43.	I/O	-	-	-	15	19	C8	G4	23	294
44.	I/O	-	-	-	16	20	A7	G3	24	297
45.	I/O	-	13	15	17	21	B8	G2	25	306
46.	I/O	-	14	16	18	22	A8	G1	26	309
47.	I/O	19	15	17	19	23	B9	G5	27	318
48.	I/O	20	16	18	20	24	C9	H3	28	321
	GND	21	17	19	21	25	D9	GND**	29	-
	VCC	22	18	20	22	26	D10	VCC**	30	-
49.	I/O	23	19	21	23	27	C10	H4	31	327
50.	I/O	24	20	22	24	28	B10	H5	32	330
51.	I/O	-	21	23	25	29	A9	J2	33	333
52.	I/O	-	22	24	26	30	A10	J1	34	339
53.	I/O	-	-	-	27	31	A11	J3	35	342
54.	I/O	-	-	-	28	32	C11	J4	36	345
	-	-	-	-	-	-	-	-	37*	-
55.	I/O	-	-	-	-	-	D11	J5	38	351
56.	I/O	-	-	-	-	-	D12	K1	39	354
	VCC	-	-	-	-	-	-	VCC**	40	-
57.	I/O	25	23	25	29	33	B11	K2	41	357
58.	I/O	26	24	26	30	34	A12	K3	42	363
59.	I/O	-	25	27	31	35	B12	J6	43	366
60.	I/O	-	26	28	32	36	A13	L1	44	369
	GND	-	27	29	33	37	C12	GND**	45	-
61.	I/O	-	-	-	-	-	D13	L2	46	375
62.	I/O	-	-	-	-	-	D14	K4	47	378
63.	I/O	-	-	-	-	38	B13	L3	48	381
64.	I/O	-	-	-	-	39	A14	M1	49	387
65.	I/O	-	-	30	34	40	A15	K5	50	390
66.	I/O	-	-	31	35	41	C13	M2	51	393
67.	I/O	27	28	32	36	42	B14	L4	52	399
68.	I/O	-	29	33	37	43	A16	N1	53	402
69.	I/O	-	30	34	38	44	B15	M3	54	405
70.	I/O	-	31	35	39	45	C14	N2	55	411
71.	I/O	28	32	36	40	46	A17	K6	56	414
72.	I/O	29	33	37	41	47	B16	P1	57	417
73.	M1 (I/O)	30	34	38	42	48	C15	N3	58	426
	GND	31	35	39	43	49	D15	GND**	59	-
74.	M0 (I/O)	32	36	40	44	50	A18	P2	60	429
	-	-	-	-	-	51*	-	-	-	-
	-	-	-	-	-	52*	-	-	-	-
	-	-	-	-	-	53*	-	-	-	-
	-	-	-	-	-	54*	-	-	-	-
	VCC	33	37	41	45	55	D16	VCC**	61	-

Pin Locations for XC5210 Devices

Pin	Description †	PC84	TQ144	PQ160	TQ176	PQ208	PG223	BG225	PQ240	Boundary Scan Order
75.	M2 (I/O)	34	38	42	46	56	C16	M4	62	432
76.	GCK2 (I/O)	35	39	43	47	57	B17	R2	63	435
77.	I/O (HDC)	36	40	44	48	58	E16	P3	64	444
78.	I/O	-	41	45	49	59	C17	L5	65	447
79.	I/O	-	42	46	50	60	D17	N4	66	450
80.	I/O	-	43	47	51	61	B18	R3	67	456
81.	I/O (LDC)	37	44	48	52	62	E17	P4	68	459
82.	I/O	-	-	49	53	63	F16	K7	69	462
83.	I/O	-	-	50	54	64	C18	M5	70	468
84.	I/O	-	-	-	-	65	D18	R4	71	471
85.	I/O	-	-	-	-	66	F17	N5	72	474
86.	I/O	-	-	-	-	-	E15	P5	73	480
87.	I/O	-	-	-	-	-	F15	L6	74	483
	GND	-	45	51	55	67	G16	GND**	75	-
88.	I/O	-	46	52	56	68	E18	R5	76	486
89.	I/O	-	47	53	57	69	F18	M6	77	492
90.	I/O	38	48	54	58	70	G17	N6	78	495
91.	I/O	39	49	55	59	71	G18	P6	79	504
	VCC	-	-	-	-	-	-	VCC**	80	-
92.	I/O	-	-	-	60	72	H16	R6	81	507
93.	I/O	-	-	-	61	73	H17	M7	82	510
	-	-	-	-	-	-	-	-	83*	-
94.	I/O	-	-	-	-	-	G15	N7	84	516
95.	I/O	-	-	-	-	-	H15	P7	85	519
96.	I/O	-	50	56	62	74	H18	R7	86	522
97.	I/O	-	51	57	63	75	J18	L7	87	528
98.	I/O	40	52	58	64	76	J17	N8	88	531
99.	I/O (ERR, INIT)	41	53	59	65	77	J16	P8	89	534
	VCC	42	54	60	66	78	J15	VCC**	90	-
	GND	43	55	61	67	79	K15	GND**	91	-
100.	I/O	44	56	62	68	80	K16	L8	92	540
101.	I/O	45	57	63	69	81	K17	P9	93	543
102.	I/O	-	58	64	70	82	K18	R9	94	546
103.	I/O	-	59	65	71	83	L18	N9	95	552
104.	I/O	-	-	-	72	84	L17	M9	96	555
105.	I/O	-	-	-	73	85	L16	L9	97	558
	-	-	-	-	-	-	-	-	98*	-
106.	I/O	-	-	-	-	-	L15	R10	99	564
107.	I/O	-	-	-	-	-	M15	P10	100	567
	VCC	-	-	-	-	-	-	VCC**	101	-
108.	I/O	46	60	66	74	86	M18	N10	102	570
109.	I/O	47	61	67	75	87	M17	K9	103	576
110.	I/O	-	62	68	76	88	N18	R11	104	579
111.	I/O	-	63	69	77	89	P18	P11	105	588
	GND	-	64	70	78	90	M16	GND**	106	-
112.	I/O	-	-	-	-	-	N15	M10	107	591
113.	I/O	-	-	-	-	-	P15	N11	108	600
114.	I/O	-	-	-	-	91	N17	R12	109	603
115.	I/O	-	-	-	-	92	R18	L10	110	606
116.	I/O	-	-	71	79	93	T18	P12	111	612

9941759 0007749 697

Pin Locations for XC5210 Devices

Pin	Description †	PC84	TQ144	PQ160	TQ176	PQ208	PG223	BG225	PQ240	Boundary Scan Order
117.	I/O	-	-	72	80	94	P17	M11	112	615
118.	I/O	48	65	73	81	95	N16	R13	113	618
119.	I/O	49	66	74	82	96	T17	N12	114	624
120.	I/O	-	67	75	83	97	R17	P13	115	627
121.	I/O	-	68	76	84	98	P16	K10	116	630
122.	I/O	50	69	77	85	99	U18	R14	117	636
123.	I/O	51	70	78	86	100	T16	N13	118	639
	GND	52	71	79	87	101	R16	GND**	119	-
	-	-	-	-	-	102*	-	-	-	-
	DONE	53	72	80	88	103	U17	P14	120	-
	-	-	-	-	-	104*	-	-	-	-
	-	-	-	-	-	105*	-	-	-	-
	VCC	54	73	81	89	106	R15	VCC**	121	-
	-	-	-	-	-	107*	-	-	-	-
	PROG	55	74	82	90	108	V18	M12	122	-
124.	I/O (D7)	56	75	83	91	109	T15	P15	123	648
125.	GCK3 (I/O)	57	76	84	92	110	U16	N14	124	651
126.	I/O	-	77	85	93	111	T14	L11	125	660
127.	I/O	-	78	86	94	112	U15	M13	126	663
128.	I/O	-	-	-	-	-	R14	N15	127	666
129.	I/O	-	-	-	-	-	R13	M14	128	672
130.	I/O (D6)	58	79	87	95	113	V17	J10	129	675
131.	I/O	-	80	88	96	114	V16	L12	130	678
132.	I/O	-	-	89	97	115	T13	M15	131	684
133.	I/O	-	-	90	98	116	U14	L13	132	687
134.	I/O	-	-	-	-	117	V15	L14	133	690
135.	I/O	-	-	-	-	118	V14	K11	134	696
	GND	-	81	91	99	119	T12	GND**	135	-
136.	I/O	-	-	-	-	-	R12	L15	136	699
137.	I/O	-	-	-	-	-	R11	K12	137	708
138.	I/O	-	82	92	100	120	U13	K13	138	711
139.	I/O	-	83	93	101	121	V13	K14	139	714
	VCC	-	-	-	-	-	-	VCC**	140	-
140.	I/O (D5)	59	84	94	102	122	U12	K15	141	720
141.	I/O (CS0)	60	85	95	103	123	V12	J12	142	723
	-	-	-	-	-	-	-	-	143*	-
142.	I/O	-	-	-	104	124	T11	J13	144	726
143.	I/O	-	-	-	105	125	U11	J14	145	732
144.	I/O	-	86	96	106	126	V11	J15	146	735
145.	I/O	-	87	97	107	127	V10	J11	147	738
146.	I/O (D4)	61	88	98	108	128	U10	H13	148	744
147.	I/O	62	89	99	109	129	T10	H14	149	747
	VCC	63	90	100	110	130	R10	VCC**	150	-
	GND	64	91	101	111	131	R9	GND**	151	-
148.	I/O (D3)	65	92	102	112	132	T9	H12	152	756
149.	I/O (RS)	66	93	103	113	133	U9	H11	153	759
150.	I/O	-	94	104	114	134	V9	G14	154	768
151.	I/O	-	95	105	115	135	V8	G15	155	771
152.	I/O	-	-	-	116	136	U8	G13	156	780
153.	I/O	-	-	-	117	137	T8	G12	157	783



Pin Locations for XC5210 Devices

Pin	Description †	PC84	TQ144	PQ160	TQ176	PQ208	PG223	BG225	PQ240	Boundary Scan Order
-	-	-	-	-	-	-	-	-	158*	-
154.	I/O (D2)	67	96	106	118	138	V7	G11	159	786
155.	I/O	68	97	107	119	139	U7	F15	160	792
	VCC	-	-	-	-	-	-	VCC**	161	-
156.	I/O	-	98	108	120	140	V6	F14	162	795
157.	I/O	-	99	109	121	141	U6	F13	163	798
158.	I/O	-	-	-	-	-	R8	G10	164	804
159.	I/O	-	-	-	-	-	R7	E15	165	807
	GND	-	100	110	122	142	T7	GND**	166	-
160.	I/O	-	-	-	-	-	R6	E14	167	810
161.	I/O	-	-	-	-	-	R5	F12	168	816
162.	I/O	-	-	-	-	143	V5	E13	169	819
163.	I/O	-	-	-	-	144	V4	D15	170	822
164.	I/O	-	-	111	123	145	U5	F11	171	828
165.	I/O	-	-	112	124	146	T6	D14	172	831
166.	I/O (D1)	69	101	113	125	147	V3	E12	173	834
167.	I/O (RCLK-BUSY/RDY)	70	102	114	126	148	V2	C15	174	840
168.	I/O	-	103	115	127	149	U4	D13	175	843
169.	I/O	-	104	116	128	150	T5	C14	176	846
170.	I/O (D0, DIN)	71	105	117	129	151	U3	F10	177	855
171.	I/O (DOUT)	72	106	118	130	152	T4	B15	178	858
	CCLK	73	107	119	131	153	V1	C13	179	-
	VCC	74	108	120	132	154	R4	VCC**	180	-
-	-	-	-	-	-	155*	-	-	-	-
-	-	-	-	-	-	156*	-	-	-	-
-	-	-	-	-	-	157*	-	-	-	-
-	-	-	-	-	-	158*	-	-	-	-
172.	I/O (TDO)	75	109	121	133	159	U2	A15	181	-
	GND	76	110	122	134	160	R3	GND**	182	-
173.	I/O (A0, WS)	77	111	123	135	161	T3	A14	183	9
174.	GCK4 (A1, I/O)	78	112	124	136	162	U1	B13	184	15
175.	I/O	-	113	125	137	163	P3	E11	185	18
176.	I/O	-	114	126	138	164	R2	C12	186	21
177.	I/O (CS1, A2)	79	115	127	139	165	T2	A13	187	27
178.	I/O (A3)	80	116	128	140	166	N3	B12	188	30
179.	I/O	-	-	-	-	-	P4	F9	189	33
180.	I/O	-	-	-	-	-	N4	D11	190	39
181.	I/O	-	117	129	141	167	P2	A12	191	42
182.	I/O	-	-	130	142	168	T1	C11	192	45
183.	I/O	-	-	-	-	169	R1	B11	193	51
184.	I/O	-	-	-	-	170	N2	E10	194	54
-	-	-	-	-	-	-	-	GND**	195*	-
	GND	-	118	131	143	171	M3	-	196	-
185.	I/O	-	119	132	144	172	P1	A11	197	57
186.	I/O	-	120	133	145	173	N1	D10	198	66
187.	I/O	-	-	-	-	-	M4	C10	199	69
188.	I/O	-	-	-	-	-	L4	B10	200	75
	VCC	-	-	-	-	-	-	VCC**	201	-
189.	I/O (A4)	81	121	134	146	174	M2	A10	202	78
190.	I/O (A5)	82	122	135	147	175	M1	D9	203	81

Pin Locations for XC5210 Devices

Pin	Description †	PC84	TQ144	PQ160	TQ176	PQ208	PG223	BG225	PQ240	Boundary Scan Order
	-	-	-	-	-	-	-	-	204*	-
191.	I/O	-	-	-	148	176	L3	C9	205	87
192.	I/O	-	-	136	149	177	L2	B9	206	90
193.	I/O	-	123	137	150	178	L1	A9	207	93
194.	I/O	-	124	138	151	179	K1	E9	208	99
195.	I/O (A6)	83	125	139	152	180	K2	C8	209	102
196.	I/O (A7)	84	126	140	153	181	K3	B8	210	105
	GND	1	127	141	154	182	K4	GND**	211	-

Notes: * Indicates unconnected package pins.

† leading numbers refer to bonded pad, shown in Figure 24 or Figure 25.

** Pins labeled VCC** are internally bonded to a VCC plane within the BG225 package. The external pins are: B2, D8, H15, R8, B14, R1, H1, and R15.

Pins labeled GND** are internally bonded to a ground plane within the BG225 package. The external pins are: A1, D12, G7, G9, H9, H8, H10, J8, K8, A8, F8, G8, H2, H7, H9, J7, J9, M8.

Boundary Scan Bit 0 = TDO.T

Boundary Scan Bit 1 = TDO.O

Boundary Scan Bit 1056 = BSCAN.UPD

Pin Locations for XC5215 Devices

Pin	Description †	PQ160	HQ208	HQ240	PG299	HQ304	BG225	BG352	Boundary Scan Order
	VCC	142	183	212	K1	38	VCC**	VCC**	-
1.	I/O (A8)	143	184	213	K2	37	E8	D14	138
2.	I/O (A9)	144	185	214	K3	36	B7	C14	141
3.	I/O	145	186	215	K5	35	A7	A15	147
4.	I/O	146	187	216	K4	34	C7	B15	150
5.	I/O	-	188	217	J1	33	D7	C15	153
6.	I/O	-	189	218	J2	32	E7	D15	159
	-	-	-	219*	-	-	-	-	-
7.	I/O (A10)	147	190	220	H1	31	A6	A16	162
8.	I/O (A11)	148	191	221	J3	30	B6	B16	165
	-	-	-	-	-	29*	-	-	-
	-	-	-	-	-	28*	-	-	-
9.	I/O	-	-	-	H2	27	-	C17	171
10.	I/O	-	-	-	G1	26	-	B18	174
	VCC	-	-	222	E1	25	VCC**	VCC**	-
	-	-	-	-	-	24*	-	-	-
11.	I/O	-	-	223	H3	23	C6	C18	177
12.	I/O	-	-	224	G2	22	F7	D17	183
13.	I/O	149	192	225	H4	21	A5	A20	186
14.	I/O	150	193	226	F2	20	B5	B19	189
	GND	151	194	227	F1	19	GND**	GND**	-
15.	I/O	-	-	-	H5	18	-	C19	195
16.	I/O	-	-	-	G3	17	-	D18	198
17.	I/O	-	195	228	D1	16	D6	A21	201
18.	I/O	-	196	229	G4	15	C5	B20	207
19.	I/O	152	197	230	E2	14	A4	C20	210
20.	I/O	153	198	231	F3	13	E6	B21	213
21.	I/O (A12)	154	199	232	G5	12	B4	B22	219
	-	-	-	-	-	11*	-	-	-
22.	I/O (A13)	155	200	233	C1	10	D5	C21	222
23.	I/O	-	-	-	F4	9	-	D20	225
24.	I/O	-	-	-	E3	8	-	A23	234
25.	I/O	-	-	234	D2	7	A3	D21	237
26.	I/O	-	-	235	C2	6	C4	C22	243
27.	I/O	156	201	236	F5	5	B3	B24	246
28.	I/O	157	202	237	E4	4	F6	C23	249
29.	I/O (A14)	158	203	238	D3	3	A2	D22	258
30.	I/O (A15)	159	204	239	C3	2	C3	C24	261
	VCC	160	205	240	A2	1	VCC**	VCC**	-
	-	-	206*	-	-	-	-	-	-
	-	-	207*	-	-	-	-	-	-
	-	-	208*	-	-	-	-	-	-
	-	-	1*	-	-	-	-	-	-
	GND	1	2	1	B1	304	GND**	GND**	-
	-	-	3*	-	-	-	-	-	-
31.	GCK1 (A16, I/O)	2	4	2	D4	303	D4	D23	270
32.	I/O (A17)	3	5	3	B2	302	B1	C25	273
33.	I/O	4	6	4	B3	301	C2	D24	279
34.	I/O	5	7	5	E6	300	E5	E23	282
35.	I/O (TDI)	6	8	6	D5	299	D3	C26	285

Pin Locations for XC5215 Devices

Pin	Description †	PQ160	HQ208	HQ240	PG299	HQ304	BG225	BG352	Boundary Scan Order
36.	I/O (TCK)	7	9	7	C4	298	C1	E24	294
37.	I/O	-	-	-	A3	297	-	F24	297
38.	I/O	-	-	-	D6	296	-	E25	303
39.	I/O	8	10	8	E7	295	D2	D26	306
40.	I/O	9	11	9	B4	294	G6	G24	309
41.	I/O	-	12	10	C5	293	E4	F25	315
42.	I/O	-	13	11	A4	292	D1	F26	318
43.	I/O	-	-	12	D7	291	E3	H23	321
44.	I/O	-	-	13	C6	290	E2	H24	327
45.	I/O	-	-	-	E8	289	-	G25	330
46.	I/O	-	-	-	B5	288	-	G26	333
	GND	10	14	14	A5	287	GND**	GND**	-
47.	I/O	11	15	15	B6	286	F5	J23	339
48.	I/O	12	16	16	D8	285	E1	J24	342
49.	I/O (TMS)	13	17	17	C7	284	F4	H25	345
50.	I/O	14	18	18	B7	283	F3	K23	351
	VCC	-	-	19	A6	282	VCC**	VCC**	-
	-	-	-	-	-	281*	-	-	-
51.	I/O	-	-	20	C8	280	F2	L24	354
52.	I/O	-	-	21	E9	279	F1	K25	357
	-	-	-	22*	-	-	-	-	-
	-	-	-	-	-	278*	-	-	-
	-	-	-	-	-	277*	-	-	-
53.	I/O	-	-	-	B8	276	-	L25	363
54.	I/O	-	-	-	A8	275	-	L26	366
55.	I/O	-	19	23	C9	274	G4	M23	369
56.	I/O	-	20	24	B9	273	G3	M24	375
57.	I/O	15	21	25	E10	272	G2	M25	378
58.	I/O	16	22	26	A9	271	G1	M26	381
59.	I/O	17	23	27	D10	270	G5	N24	390
60.	I/O	18	24	28	C10	269	H3	N25	393
	GND	19	25	29	A10	268	GND**	GND**	-
	VCC	20	26	30	A11	267	VCC**	VCC**	-
61.	I/O	21	27	31	B10	266	H4	N26	399
62.	I/O	22	28	32	B11	265	H5	P25	402
63.	I/O	23	29	33	C11	264	J2	P23	405
64.	I/O	24	30	34	E11	263	J1	P24	411
65.	I/O	-	31	35	D11	262	J3	R26	414
66.	I/O	-	32	36	A12	261	J4	R25	417
67.	I/O	-	-	-	B12	260	-	R24	423
68.	I/O	-	-	-	A13	259	-	R23	426
	-	-	-	37*	-	-	-	-	-
	-	-	-	-	-	258*	-	-	-
	-	-	-	-	-	257*	-	-	-
69.	I/O	-	-	38	E12	256	J5	T26	429
70.	I/O	-	-	39	B13	255	K1	T25	435
	-	-	-	-	-	254*	-	-	-
	VCC	-	-	40	A16	253	VCC**	VCC**	-
71.	I/O	25	33	41	A14	252	K2	U24	438
72.	I/O	26	34	42	C13	251	K3	V25	441
73.	I/O	27	35	43	B14	250	J6	V24	447

Pin Locations for XC5215 Devices

Pin	Description †	PQ160	HQ208	HQ240	PG299	HQ304	BG225	BG352	Boundary Scan Order
74.	I/O	28	36	44	D13	249	L1	U23	450
	GND	29	37	45	A15	248	GND**	GND**	-
75.	I/O	-	-	-	B15	247	-	Y26	453
76.	I/O	-	-	-	E13	246	-	W25	459
77.	I/O	-	-	46	C14	245	L2	W24	462
78.	I/O	-	-	47	A17	244	K4	V23	465
79.	I/O	-	38	48	D14	243	L3	AA26	471
80.	I/O	-	39	49	B16	242	M1	Y25	474
81.	I/O	30	40	50	C15	241	K5	Y24	477
82.	I/O	31	41	51	E14	240	M2	AA25	483
83.	I/O	-	-	-	A18	239	-	AB25	486
84.	I/O	-	-	-	D15	238	-	AA24	489
85.	I/O	32	42	52	C16	237	L4	Y23	495
86.	I/O	33	43	53	B17	236	N1	AC26	498
87.	I/O	34	44	54	B18	235	M3	AA23	501
88.	I/O	35	45	55	E15	234	N2	AB24	507
89.	I/O	36	46	56	D16	233	K6	AD25	510
90.	I/O	37	47	57	C17	232	P1	AC24	513
91.	M1 (I/O)	38	48	58	A20	231	N3	AB23	522
	GND	39	49	59	A19	230	GND**	GND**	-
92.	M0 (I/O)	40	50	60	C18	229	P2	AD24	525
	-	-	51*	-	-	-	-	-	-
	-	-	52*	-	-	-	-	-	-
	-	-	53*	-	-	-	-	-	-
	-	-	54*	-	-	-	-	-	-
	VCC	41	55	61	B20	228	VCC**	VCC**	-
93.	M2 (I/O)	42	56	62	D17	227	M4	AC23	528
94.	GCK2 (I/O)	43	57	63	B19	226	R2	AE24	531
95.	I/O (HDC)	44	58	64	C19	225	P3	AD23	540
96.	I/O	45	59	65	F16	224	L5	AC22	543
97.	I/O	46	60	66	E17	223	N4	AF24	546
98.	I/O	47	61	67	D18	222	R3	AD22	552
99.	I/O (LDC)	48	62	68	C20	221	P4	AE23	555
100.	I/O	-	-	-	F17	220	-	AE22	558
101.	I/O	-	-	-	G16	219	-	AF23	564
102.	I/O	49	63	69	D19	218	K7	AD20	567
103.	I/O	50	64	70	E18	217	M5	AE21	570
104.	I/O	-	65	71	D20	216	R4	AF21	576
105.	I/O	-	66	72	G17	215	N5	AC19	579
106.	I/O	-	-	73	F18	214	P5	AD19	582
107.	I/O	-	-	74	H16	213	L6	AE20	588
108.	I/O	-	-	-	E19	212	-	AF20	591
109.	I/O	-	-	-	F19	211	-	AC18	594
	GND	51	67	75	E20	210	GND**	GND**	-
110.	I/O	52	68	76	H17	209	R5	AD18	600
111.	I/O	53	69	77	G18	208	M6	AE19	603
112.	I/O	54	70	78	G19	207	N6	AC17	606
113.	I/O	55	71	79	H18	206	P6	AD17	612
	-	-	-	-	-	205*	-	-	-
	VCC	-	-	80	F20	204	VCC**	VCC**	-
114.	I/O	-	72	81	J16	203	R6	AE17	615

Pin Locations for XC5215 Devices

Pin	Description †	PQ160	HQ208	HQ240	PG299	HQ304	BG225	BG352	Boundary Scan Order
115.	I/O	-	73	82	G20	202	M7	AE16	618
	-	-	-	83*	-	-	-	-	-
	-	-	-	-	-	201*	-	-	-
	-	-	-	-	-	200*	-	-	-
116.	I/O	-	-	-	H20	199	-	AF16	624
117.	I/O	-	-	-	J18	198	-	AC15	627
118.	I/O	-	-	84	J19	197	N7	AD15	630
119.	I/O	-	-	85	K16	196	P7	AE15	636
120.	I/O	56	74	86	J20	195	R7	AF15	639
121.	I/O	57	75	87	K17	194	L7	AD14	642
122.	I/O	58	76	88	K18	193	N8	AE14	648
123.	I/O (ERR, INIT)	59	77	89	K19	192	P8	AF14	651
	VCC	60	78	90	L20	191	VCC**	VCC**	-
	GND	61	79	91	K20	190	GND**	GND**	-
124.	I/O	62	80	92	L19	189	L8	AE13	660
125.	I/O	63	81	93	L18	188	P9	AC13	663
126.	I/O	64	82	94	L16	187	R9	AD13	672
127.	I/O	65	83	95	L17	186	N9	AF12	675
128.	I/O	-	84	96	M20	185	M9	AE12	678
129.	I/O	-	85	97	M19	184	L9	AD12	684
130.	I/O	-	-	-	N20	183	-	AC12	687
131.	I/O	-	-	-	M18	182	-	AF11	690
	-	-	-	98*	-	-	-	-	-
	-	-	-	-	-	181*	-	-	-
	-	-	-	-	-	180*	-	-	-
132.	I/O	-	-	99	N19	179	R10	AE11	696
133.	I/O	-	-	100	P20	178	P10	AD11	699
	VCC	-	-	101	T20	177	VCC**	VCC**	-
	-	-	-	-	-	176*	-	-	-
134.	I/O	66	86	102	N18	175	N10	AE9	702
135.	I/O	67	87	103	P19	174	K9	AD9	708
136.	I/O	68	88	104	N17	173	R11	AC10	711
137.	I/O	69	89	105	R19	172	P11	AF7	714
	GND	70	90	106	R20	171	GND**	GND**	-
138.	I/O	-	-	-	N16	170	-	AE8	720
139.	I/O	-	-	-	P18	169	-	AD8	723
140.	I/O	-	-	107	U20	168	M10	AC9	726
141.	I/O	-	-	108	P17	167	N11	AF6	732
142.	I/O	-	91	109	T19	166	R12	AE7	735
143.	I/O	-	92	110	R18	165	L10	AD7	738
144.	I/O	71	93	111	P16	164	P12	AE6	744
145.	I/O	72	94	112	V20	163	M11	AE5	747
146.	I/O	-	-	-	R17	162	-	AD6	750
147.	I/O	-	-	-	T18	161	-	AC7	756
148.	I/O	73	95	113	U19	160	R13	AF4	759
149.	I/O	74	96	114	V19	159	N12	AF3	768
150.	I/O	75	97	115	R16	158	P13	AD5	771
151.	I/O	76	98	116	T17	157	K10	AE3	774
152.	I/O	77	99	117	U18	156	R14	AD4	780
153.	I/O	78	100	118	X20	155	N13	AC5	783
	GND	79	101	119	W20	154	GND**	GND**	-

Pin Locations for XC5215 Devices

Pin	Description †	PQ160	HQ208	HQ240	PG299	HQ304	BG225	BG352	Boundary Scan Order
-	-	-	102*	-	-	-	-	-	-
-	DONE	80	103	120	V18	153	P14	AD3	-
-	-	-	104*	-	-	-	-	-	-
-	-	-	105*	-	-	-	-	-	-
-	VCC	81	106	121	X19	152	VCC**	VCC**	-
-	-	-	107*	-	-	-	-	-	-
-	PROG	82	108	122	U17	151	M12	AC4	-
154.	I/O (D7)	83	109	123	W19	150	P15	AD2	792
155.	GCK3 (I/O)	84	110	124	W18	149	N14	AC3	795
156.	I/O	85	111	125	T15	148	L11	AB4	804
157.	I/O	86	112	126	U16	147	M13	AD1	807
158.	I/O	-	-	127	V17	146	N15	AA4	810
159.	I/O	-	-	128	X18	145	M14	AA3	816
160.	I/O	-	-	-	U15	144	-	AB2	819
161.	I/O	-	-	-	T14	143	-	AC1	828
162.	I/O (D6)	87	113	129	W17	142	J10	Y3	831
163.	I/O	88	114	130	V16	141	L12	AA2	834
164.	I/O	89	115	131	X17	140	M15	AA1	840
165.	I/O	90	116	132	U14	139	L13	W4	843
166.	I/O	-	117	133	V15	138	L14	W3	846
167.	I/O	-	118	134	T13	137	K11	Y2	852
168.	I/O	-	-	-	W16	136	-	Y1	855
169.	I/O	-	-	-	W15	135	-	V4	858
-	GND	91	119	135	X16	134	GND**	GND**	-
170.	I/O	-	-	136	U13	133	L15	V3	864
171.	I/O	-	-	137	V14	132	K12	W2	867
172.	I/O	92	120	138	W14	131	K13	U4	870
173.	I/O	93	121	139	V13	130	K14	U3	876
-	VCC	-	-	140	X15	129	VCC**	VCC**	-
-	-	-	-	-	-	128*	-	-	-
174.	I/O (D5)	94	122	141	T12	127	K15	V2	879
175.	I/O (CS0)	95	123	142	X14	126	J12	V1	882
-	-	-	-	143*	-	-	-	-	-
-	-	-	-	-	-	125*	-	-	-
-	-	-	-	-	-	124*	-	-	-
176.	I/O	-	-	-	X13	123	-	T1	888
177.	I/O	-	-	-	V12	122	-	R4	891
178.	I/O	-	124	144	W12	121	J13	R3	894
179.	I/O	-	125	145	T11	120	J14	R2	900
180.	I/O	96	126	146	X12	119	J15	R1	903
181.	I/O	97	127	147	U11	118	J11	P3	906
182.	I/O (D4)	98	128	148	V11	117	H13	P2	912
183.	I/O	99	129	149	W11	116	H14	P1	915
-	VCC	100	130	150	X10	115	VCC**	VCC**	-
-	GND	101	131	151	X11	114	GND**	GND**	-
184.	I/O (D3)	102	132	152	W10	113	H12	N2	924
185.	I/O (RS)	103	133	153	V10	112	H11	N4	927
186.	I/O	104	134	154	T10	111	G14	N3	936
187.	I/O	105	135	155	U10	110	G15	M1	939
188.	I/O	-	136	156	X9	109	G13	M2	942
189.	I/O	-	137	157	W9	108	G12	M3	948

Pin Locations for XC5215 Devices

Pin	Description †	PQ160	HQ208	HQ240	PG299	HQ304	BG225	BG352	Boundary Scan Order
190.	I/O	-	-	-	X8	107	-	M4	951
191.	I/O	-	-	-	V9	106	-	L1	954
	-	-	-	158*	-	-	-	-	-
	-	-	-	-	-	105*	-	-	-
	-	-	-	-	-	104*	-	-	-
192.	I/O (D2)	106	138	159	W8	103	G11	J1	960
193.	I/O	107	139	160	X7	102	F15	K3	963
	VCC	-	-	161	X5	101	VCC**	VCC**	-
	-	-	-	-	-	100*	-	-	-
194.	I/O	108	140	162	V8	99	F14	J2	966
195.	I/O	109	141	163	W7	98	F13	J3	972
196.	I/O	-	-	164	U8	97	G10	K4	975
197.	I/O	-	-	165	W6	96	E15	G1	978
	GND	110	142	166	X6	95	GND**	GND**	-
198.	I/O	-	-	-	T8	94	-	H2	984
199.	I/O	-	-	-	V7	93	-	H3	987
200.	I/O	-	-	167	X4	92	E14	J4	990
201.	I/O	-	-	168	U7	91	F12	F1	996
202.	I/O	-	143	169	W5	90	E13	G2	999
203.	I/O	-	144	170	V6	89	D15	G3	1002
204.	I/O	111	145	171	T7	88	F11	F2	1008
205.	I/O	112	146	172	X3	87	D14	E2	1011
206.	I/O (D1)	113	147	173	U6	86	E12	F3	1014
207.	I/O (RCLK-BUSY/RDY)	114	148	174	V5	85	C15	G4	1020
208.	I/O	-	-	-	W4	84	-	D2	1023
209.	I/O	-	-	-	W3	83	-	F4	1032
210.	I/O	115	149	175	T6	82	D13	E3	1035
211.	I/O	116	150	176	U5	81	C14	C2	1038
212.	I/O (D0, DIN)	117	151	177	V4	80	F10	D3	1044
213.	I/O (DOUT)	118	152	178	X1	79	B15	E4	1047
	CCLK	119	153	179	V3	78	C13	C3	-
	VCC	120	154	180	W1	77	VCC**	VCC**	-
	-	-	155*	-	-	-	-	-	-
	-	-	156*	-	-	-	-	-	-
	-	-	157*	-	-	-	-	-	-
	-	-	158*	-	-	-	-	-	-
214.	I/O (TDO)	121	159	181	U4	76	A15	D4	0
	GND	122	160	182	X2	75	GND**	GND**	-
215.	I/O (A0, WS)	123	161	183	W2	74	A14	B3	9
216.	GCK4 (A1, I/O)	124	162	184	V2	73	B13	C4	15
217.	I/O	125	163	185	R5	72	E11	D5	18
218.	I/O	126	164	186	T4	71	C12	A3	21
219.	I/O (A2, CS1)	127	165	187	U3	70	A13	D6	27
220.	I/O (A3)	128	166	188	V1	69	B12	C6	30
221.	I/O	-	-	-	R4	68	-	B5	33
222.	I/O	-	-	-	P5	67	-	A4	39
223.	I/O	-	-	189	U2	66	F9	C7	42
224.	I/O	-	-	190	T3	65	D11	B6	45
225.	I/O	129	167	191	U1	64	A12	A6	51
226.	I/O	130	168	192	P4	63	C11	D8	54
227.	I/O	-	169	193	R3	62	B11	B7	57

Pin Locations for XC5215 Devices

Pin	Description †	PQ160	HQ208	HQ240	PG299	HQ304	BG225	BG352	Boundary Scan Order
228.	I/O	-	170	194	N5	61	E10	A7	63
229.	I/O	-	-	195	T2	60	-	D9	66
230.	I/O	-	-	-	R2	59	-	C9	69
	GND	131	171	196	T1	58	GND**	GND**	-
231.	I/O	132	172	197	N4	57	A11	B8	75
232.	I/O	133	173	198	P3	56	D10	D10	78
233.	I/O	-	-	199	P2	55	C10	C10	81
234.	I/O	-	-	200	N3	54	B10	B9	87
	-	-	-	-	-	53*	-	-	-
	VCC	-	-	201	R1	52	VCC**	VCC**	-
235.	I/O	-	-	-	M5	51	-	B11	90
236.	I/O	-	-	-	P1	50	-	A11	93
	-	-	-	-	-	49*	-	-	-
	-	-	-	-	-	48*	-	-	-
237.	I/O (A4)	134	174	202	N1	47	A10	D12	99
238.	I/O (A5)	135	175	203	M3	46	D9	C12	102
	-	-	-	204*	-	-	-	-	-
239.	I/O	-	176	205	M2	45	C9	B12	105
240.	I/O	136	177	206	L5	44	B9	A12	111
241.	I/O	137	178	207	M1	43	A9	C13	114
242.	I/O	138	179	208	L4	42	E9	B13	117
243.	I/O (A6)	139	180	209	L3	41	C8	A13	126
244.	I/O (A7)	140	181	210	L2	40	B8	B14	129
	GND	141	182	211	L1	39	GND**	GND**	-

Notes: * Indicates unconnected package pins.

† leading numbers refer to bonded pad, shown in Figure 26, Figure 27 or Figure 28.

** Pins labeled VCC** are internally bonded to a VCC plane within the BG225 and BG352 packages. The external pins for the BG225 are: B2, D8, H15, R8, B14, E1, and R15. The external pins for the BG352 are: A10, A17, B2, B25, D13, D19, D7, G23, H4, K1, K26, N23, P4, U1, U26, W23, Y4, AC14, AC20, AC8, AE2, AE25, AF10, and AF17.

Pins labeled GND** are internally bonded to a ground plane within the BG225 and BG352 packages. The external pins for the BG225 are: A1, D12, G7, G9, H9, H8, H10, J8, K8, A8, F8, G8, H2, H7, H9, J7, J9, M8. The external pins for the BG352 are: A1, A2, A5, A8, A14, A19, A22, A25, A26, B1, B26, E1, E26, H1, H26, N1, P26, W1, W26, AB1, AB26, AE1, AE26, AF1, AF13, AF19, AF2, AF22, AF25, AF26, AF5, AF8.

Boundary Scan Bit 0 = TDO.T

Boundary Scan Bit 1 = TDO.O

Boundary Scan Bit 1056 = BSCAN.UPD

Product Availability

PINS TYPE CODE	84	100	100	144	156	160	176	191	208	208	223	225	240	240	299	304	352
	Plast. PLCC	Plast. PQFP	Plast. VQFP	Plast. TQFP	Ceram. PGA	Plast. PQFP	Plast. TQFP	Ceram. PGA	High- Perf. QFP	Plast. PQFP	Ceram. PGA	Plast. BGA	High- Perf. QFP	Plast. PQFP	Ceram. PGA	High- Perf. QFP	Plast. BGA
	PC84	PQ100	VQ100	TQ144	PG156	PQ160	TQ176	PG191	HQ208	PQ208	PG223	BG225	HQ240	PQ240	PG299	HQ304	BG352
XC5202	-6	CI	CI	CI	CI	CI											
	-5	CI	CI	CI	CI	CI											
	-4	(CI)	(CI)	(CI)	(CI)	(CI)											
	-3	(CI)	(CI)	(CI)	(CI)	(CI)											
XC5204	-6	CI	CI	CI	CI	CI	CI										
	-5	CI	CI	CI	CI	CI	CI										
	-4	(CI)	(CI)	(CI)	(CI)	(CI)	(CI)										
	-3	(CI)	(CI)	(CI)	(CI)	(CI)	(CI)										
XC5206	-6	CI	CI	CI	CI	CI	CI	CI	CI	CI							
	-5	CI	CI	CI	CI	CI	CI	CI	CI	CI							
	-4	(CI)	(CI)	(CI)	(CI)	(CI)	(CI)	(CI)	(CI)	(CI)							
	-3	(CI)	(CI)	(CI)	(CI)	(CI)	(CI)	(CI)	(CI)	(CI)							
XC5210	-6	CI			CI	CI	CI	CI		CI	CI	CI		CI			
	-5	CI			CI	CI	CI			CI	CI	CI		CI			
	-4	(CI)			(CI)	(CI)	(CI)			(CI)	(CI)	(CI)		(CI)			
	-3	(CI)			(CI)	(CI)	(CI)			(CI)	(CI)	(CI)		(CI)			
XC5215	-6					CI			CI			CI	CI		CI	CI	CI
	-5					CI			CI			CI	CI		CI	CI	CI
	-4					(CI)			(CI)			(CI)	(CI)		(CI)	(CI)	(CI)
	-3					(CI)			(CI)			(CI)	(CI)		(CI)	(CI)	(CI)

Notes: Parentheses indicate future product plans C = Commercial T_J = 0° to +85°C I = Industrial T_J = -40°C to +100°C

User I/O Per Package

Device	Max I/O	Package Type															
		PC84	PQ100	VQ100	TQ144	PG156	PQ160	TQ176	PG191	HQ208	PQ208	PG223	BG225	HQ240	PQ240	PG299	HQ304
XC5202	84	65	81	81	84	84											
XC5204	124	65	81	81	117	124	124										
XC5206	148	65	81	81	117		133	148	148		148						
XC5210	196	65			117		133	149			164	196	196	196			
XC5215	244						133			164		196	197		244	244	244

Ordering Information

Example: **XC5210-6PQ208C**

